

MX•COM, INC. MiXed Signal ICs

DATA BULLETIN

MX465

**LOW VOLTAGE
CTCSS ENCODER/DECODER**
with Tx and Rx Audio Filters

Features

- Meets TIA/EIA-603 Standards
- 47 CTCSS Tones + Notone
- TX/RX Speech Filters
- Improved Sinad
- Serial or Parallel Programming
- Easy μ P Interface
- Scanning on any Channel
- Standard 4MHz Xtal
(See MX165C for 1MHz)
- Low Voltage 3.3V to 5.0V

Applications

- Mobile Radio Channel Sharing
- Scan Trunking
- Wireless Intercom Traffic Control
- Hookswitch Supervision
- Repeater Control

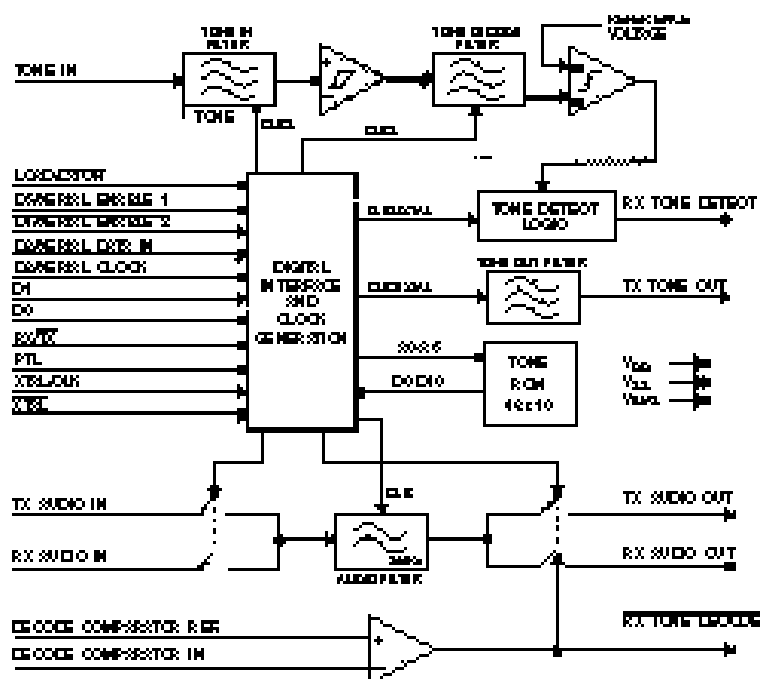

The MX465 CTCSS Encoder/Decoder is a low voltage, CMOS device that meets TIA/EIA-603 Standards. The MX465 will encode and decode the tones 159.8Hz, 183.5Hz, 189.9Hz, 196.6Hz, 199.5Hz, 206.5Hz, 229.1Hz, and 254.1Hz in addition to the 39 standard CTCSS tones, for a total of 47 CTCSS tones + Notone. With the incorporation of the on-chip TX and RX speech filter, the MX465 enhances voice/tone multiplexing by attenuating TX and RX speech 36dB at frequencies below 250Hz while passing signals > 300Hz with only 1dB of ripple. This not only minimizes CTCSS talk-off in the TX mode but also improves Hum and Noise performance in the RX mode.

Available in the following package styles: 24-pin TSSOP (MX465TN), 24-pin SSOP (MX465DS), 24-pin SOIC (MX465DW), 24-pin PDIP (MX465P), and 24-pin CDIP (MX465J) the MX465 requires a single 3.3V to 5.0V supply and a 4MHz clock or crystal.

CONTENTS

Section	Page
1 Block Diagram	3
2 Signal List	4
3 External Components	6
4 General Description	7
4.1 Description	7
4.2 I/O Conditions	7
4.3 Filter Response.....	8
4.4 Serial and Parallel Mode Timing.....	8
4.5 CTCSS Programming.....	10
5 Performance Specification	11
5.1 Electrical Performance	11
5.1.1 Absolute Maximum Ratings	11
5.1.2 Operating Limits	12
5.1.3 Operating Characteristics.....	12
5.2 Packaging.....	14

MX-COM, Inc. Reserves the right to change specifications at any time and without notice

1 Block Diagram

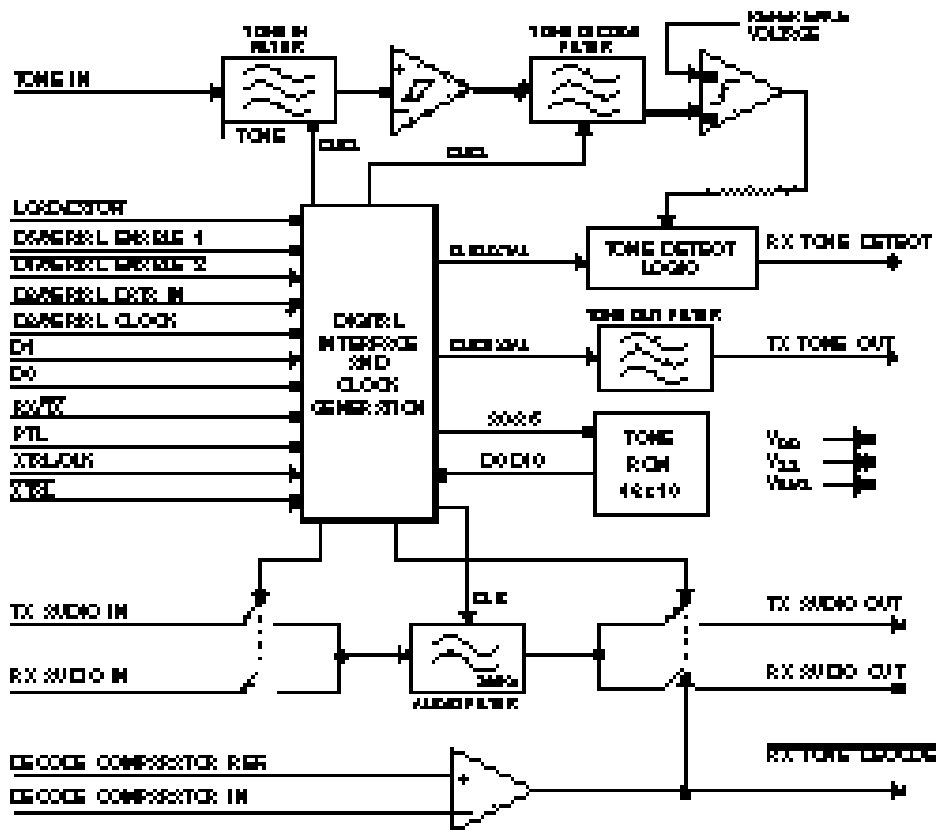

Figure 1 : Block Diagram

2 Signal List

Pin No.	Signal	Type	Description
1	V _{DD}	power	Positive supply. This pin should be bypassed to V _{SS} by a capacitor mounted close to the device pins.
2	XTAL/CLOCK	input	Input to the on-chip inverter used with a 4 MHz Xtal or external clock source.
3	$\overline{\text{XTAL}}$	output	Output of the on-chip inverter (clock output).
4	LOAD / LATCH	input	Controls 8 on-chip latches. It is used to latch RX/ $\overline{\text{TX}}$, PTL, and D0-D5. A logic 1 applied to this input places the 8 latches in the 'transparent' mode. A logic 0 applied to this input places the 8 latches in the 'latched' mode. In Parallel Mode, data is loaded and latched by a logic 1-0 transition (see Figure 4). In Serial Mode, data is loaded and latched by a 0-1-0 strobe pulse on this pin (see Figure 5). Internally pulled to V _{DD}
5	D5 / SERIAL ENABLE 1	input	Data input D5 (Parallel Mode). A logic 1 applied to this input together with a logic 0 applied to D4/SERIAL ENABLE 2 will place the device in Serial Mode (see Figure 5). Internally pulled to V _{DD} .
6	D4 / SERIAL ENABLE 2	input	Data input D4 (Parallel Mode). A logic 0 applied to this input together with a logic 1 applied to D5 / SERIAL ENABLE 1 will place the device in Serial Mode (see Figure 5). Internally pulled to V _{DD} .
7	D3 / SERIAL DATA IN	input	Data input D3 (Parallel Mode). In Serial Mode this pin becomes the serial data input for D5-D0, RX/ $\overline{\text{TX}}$ and PTL (see Figure 5). D5 is clocked first and PTL last. Internally pulled to V _{DD} .
8	D2 / SERIAL CLOCK	input	Data input D2 (Parallel Mode). In Serial Mode this pin becomes the SERIAL CLOCK input. Data is clocked on the positive going edge (see Figure 5). Internally pulled to V _{DD} .
9	D1	input	Data input D1 (Parallel Mode). Internally pulled to V _{DD} .
10	D0	input	Data input D0 (Parallel Mode). Internally pulled to V _{DD} .
11	V _{SS}	power	Negative supply.
12	DECODE COMPARATOR REF.	input	Internally biased to V _{DD} /3 or 2 V _{DD} /3 via 1M resistors depending on the logic state of the RX TONE DECODE pin. RX TONE DECODE = 1 will bias this input 2 V _{DD} /3; a logic 0 will bias this input V _{DD} /3. This input provides the DECODE COMPARATOR REFERENCE voltage, and the switching of bias voltages provides hysteresis to reduce 'chatter' under marginal conditions.
13	RX TONE DECODE	output	Gated output of the decode comparator. This output is used to gate the RX Audio path. A logic 0 on this pin indicates a successful decode and the DECODE COMPARATOR IN pin is more positive than the DECODE COMPARATOR REF. input (see Table 3).
14	DECODE COMPARATOR IN	input	Inverting input of the DECODE COMPARATOR. This pin is normally connected to the integrated output of the RX TONE DETECT line.

Pin No.	Signal	Type	Description
15	RX TONE DETECT	output	In RX mode this output will go to logic 1 during a successful decode. It must be externally integrated to control response and deresponse times (see Table 3).
16	TX TONE OUT	output	The CTCSS sinewave output appears on this pin under control of the RX/ $\overline{\text{TX}}$ pin. When not transmitting a tone, TX TONE OUT may be biased to $V_{DD}/2$. (see Table 3).
17	RX/ $\overline{\text{TX}}$	input	RX or TX modes selected in Parallel Mode (see Figure 4). In Serial Mode this function is serially loaded. This pin is internally pulled to V_{DD} via a $1\text{M}\Omega$ resistor.
18	PTL	input	In RX mode this pin operates as a 'Push To Listen' function by enabling the RX audio path, thus overriding the tone squelch function (Parallel Mode). In Serial Mode this function is loaded serially. Internal pull-up to V_{DD}
19	RX AUDIO OUT	output	High pass filtered RX AUDIO OUT. This pin outputs audio when RX TONE DECODE = logic 0, PTL = logic 1, or when Notone is programmed (see Table 4). In TX mode this pin is biased to $V_{DD}/2$.
20	TX AUDIO OUT	output	High pass filtered TX AUDIO OUT pin. In TX mode this pin outputs audio present at the TX AUDIO IN pin. In RX mode this pin is biased to $V_{DD}/2$
21	V_{BIAS}	output	Output of an internally generated $V_{DD}/2$ bias level that would normally be externally bypassed to V_{SS} via capacitor C6.
22	TX AUDIO IN	input	In TX mode TX AUDIO IN may be prefiltered, using the TX Audio path, thus helping to avoid talk-off due to intermodulation of speech frequencies with the transmitted CTCSS tone. Internally biased to $V_{DD}/2$.
23	RX AUDIO IN	input	Input to the audio high pass filter in RX mode. Internally biased to $V_{DD}/2$.
24	TONE INPUT	input	Input to the CTCSS tone detector. Internally biased to $V_{DD}/2$.

Table 1: Signal List

3 External Components

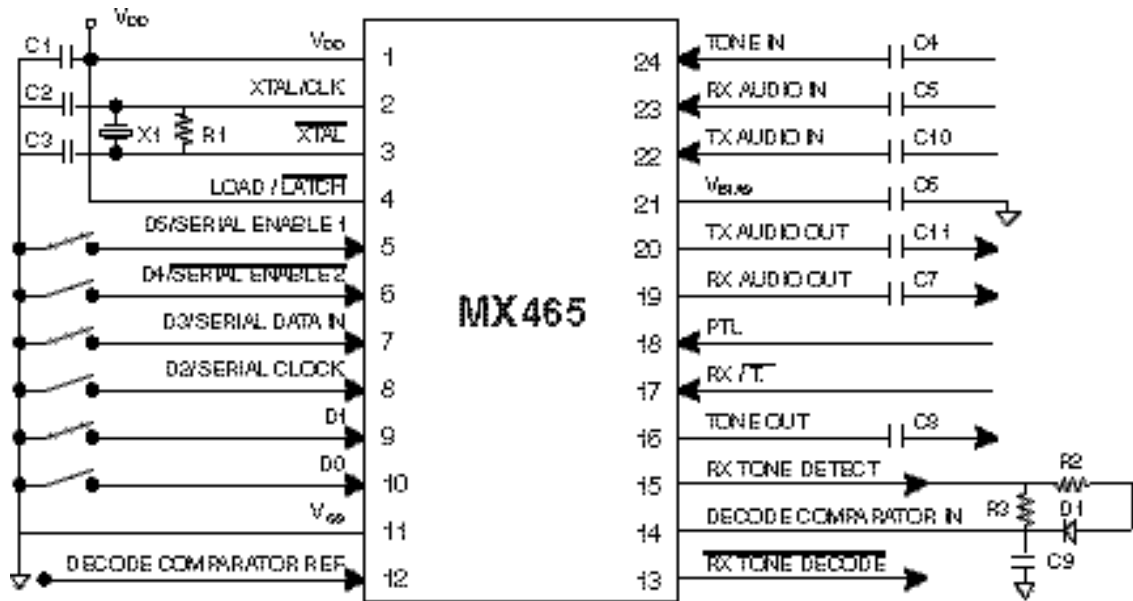

Figure 2 : Recommended External Components for Typical Application

R1	Note 1	1.0M Ω	$\pm 10\%$	C6		0.47 μF	$\pm 20\%$
R2		560k Ω	$\pm 10\%$	C7	Note 2	0.1 μF	$\pm 20\%$
R3		820k Ω	$\pm 10\%$	C8	Note 2	0.1 μF	$\pm 20\%$
C1		0.1 μF	$\pm 20\%$	C9	Note 2	0.1 μF	$\pm 20\%$
C2	Note 1	18pF	$\pm 20\%$	C10	Note 2	0.1 μF	$\pm 20\%$
C3	Note 1	33pF	$\pm 20\%$	C11	Note 2	0.1 μF	$\pm 20\%$
C4	Note 2	0.1 μF	$\pm 20\%$	D1		small signal	
C5	Note 2	0.1 μF	$\pm 20\%$	X1	Note 1	4MHz	100ppm max.

Table 2: External Components

External Components Notes:

1. The values specified for R1, C2, and C3 have been found to be satisfactory when used with a crystal (X1) whose equivalent series resistance is $\leq 1000\Omega$. For best results, a crystal oscillator design should drive the clock inverter input with signal levels of at least 40% of V_{DD} , peak to peak. Tuning fork crystals generally cannot meet this requirement. To obtain crystal oscillator design assistance, consult your crystal manufacturer.
2. The 0.1 μF value for the DC Blocking capacitors, C4, C5, C7, C8, C9, C10, and C11 is not a requirement. For the capacitors C4, C5, and C10, the input impedance is internal to the device and specified typical as 550k Ω . For the remaining capacitors external circuits will be important in determining the input impedance.

4 General Description

4.1 Description

Voice on shared radio channels are multiplexed with a subaudible CTCSS (Continuous Tone Controlled Subaudible Squelch) tone as a means of directing messages among user groups sharing the same RF frequencies. CTCSS modulates the transmitter with a discrete tone, from 39 standard CTCSS tones in the range (67.0Hz to 250.0Hz) according to TIA/EIA-603. There are an additional eight CTCSS tones not specified in TIA/EIA-603 that the MX465 will encode and decode. They are : 159.8Hz, 183.5Hz, 189.9Hz, 196.6Hz, 199.5Hz, 206.5Hz, 229.1Hz, and 254.1Hz, for a total of 47 CTCSS tones plus Notone.

The MX465 also incorporates TX/RX on chip speech filters. In early CTCSS designs, TX speech was not filtered from the CTCSS tone, rather the filtering was dependent upon the host transmitter's pre-emphasis network. At only 6dB/octave, the attenuation of speech components at higher CTCSS tones was only a few dB which resulted in talk-off (low frequency voice components unsquelching the receiver audio).

4.2 I/O Conditions

D0-D5	Tone	No Tone	Tone	Tone	Tone	No Tone
Input Pins Condition						
RX / $\overline{\text{TX}}$	0	0	1	1	1	1
PTL	0	X	0	1	X	X
Decode Comparator In	X	X	0	0	1	X
Output Pins Condition						
RX TONE DETECT	0	0	0	0	1	X
$\overline{\text{RX TONE DECODE}}$	1	1	1	1	0	0
Result / Function						
Tone Transmitter Enabled	Yes	No (Bias)	No (Bias)	No (Bias)	No (Bias)	No (Bias)
TX Audio Path Enabled	Yes	Yes	No	No	No	No
Tone Decode Enabled	No	No	Yes	Yes	Yes	Yes
RX Audio Path Enabled	No (Bias)	No (Bias)	No (Bias)	Yes	Yes	Yes
Notes	1	2	3	4	5	6

Notes:

1. Normal tone transmit condition.
2. Notone programmed in TX mode, tone transmit output set to $V_{DD}/2$. TX audio path enabled.
3. Normal decode standby.
4. Normal decode standby with PTL used to enable audio.
5. Normal decode of correct CTCSS tone condition, PTL has no effect.
6. Notone programmed in RX mode, tone transmit output (Bias). RX audio path enabled.
7. X = don't care

Table 3: Combinations of Input / Output conditions

4.3 Filter Response

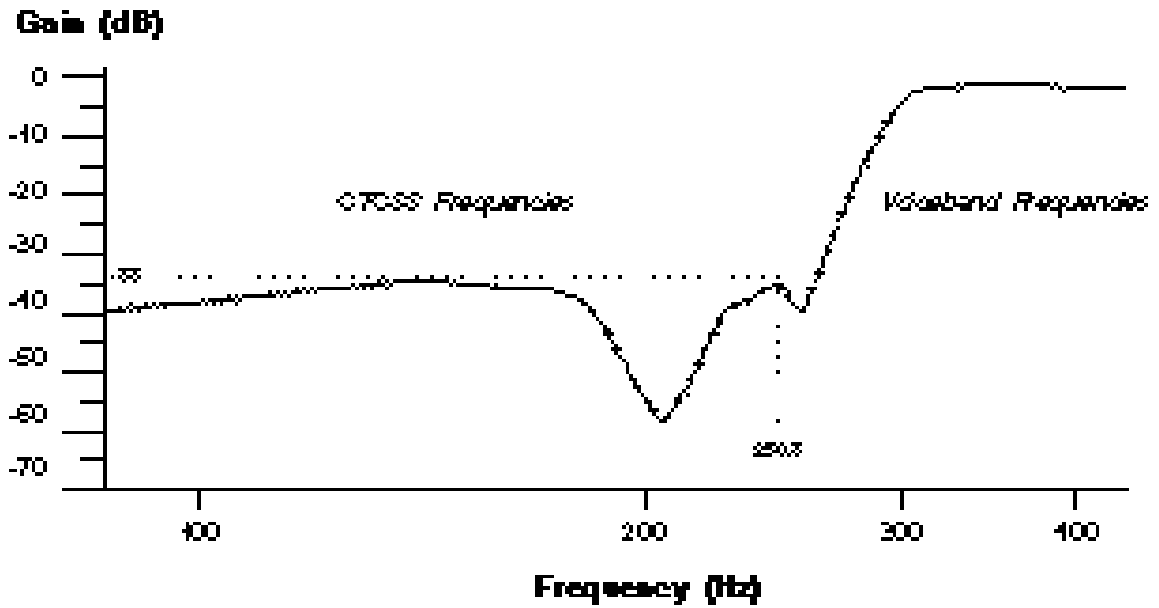

Figure 3 : Voiceband Filter Response

4.4 Serial and Parallel Mode Timing

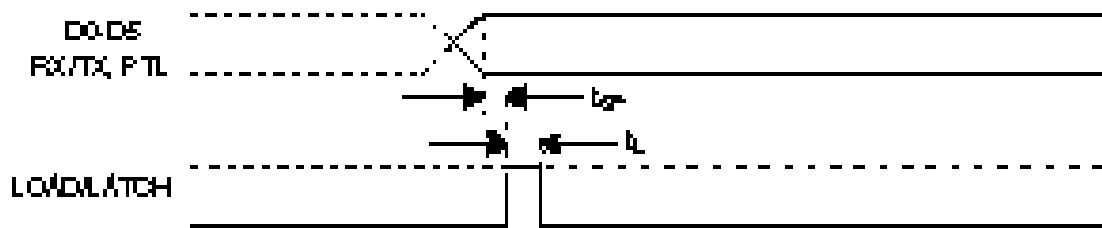
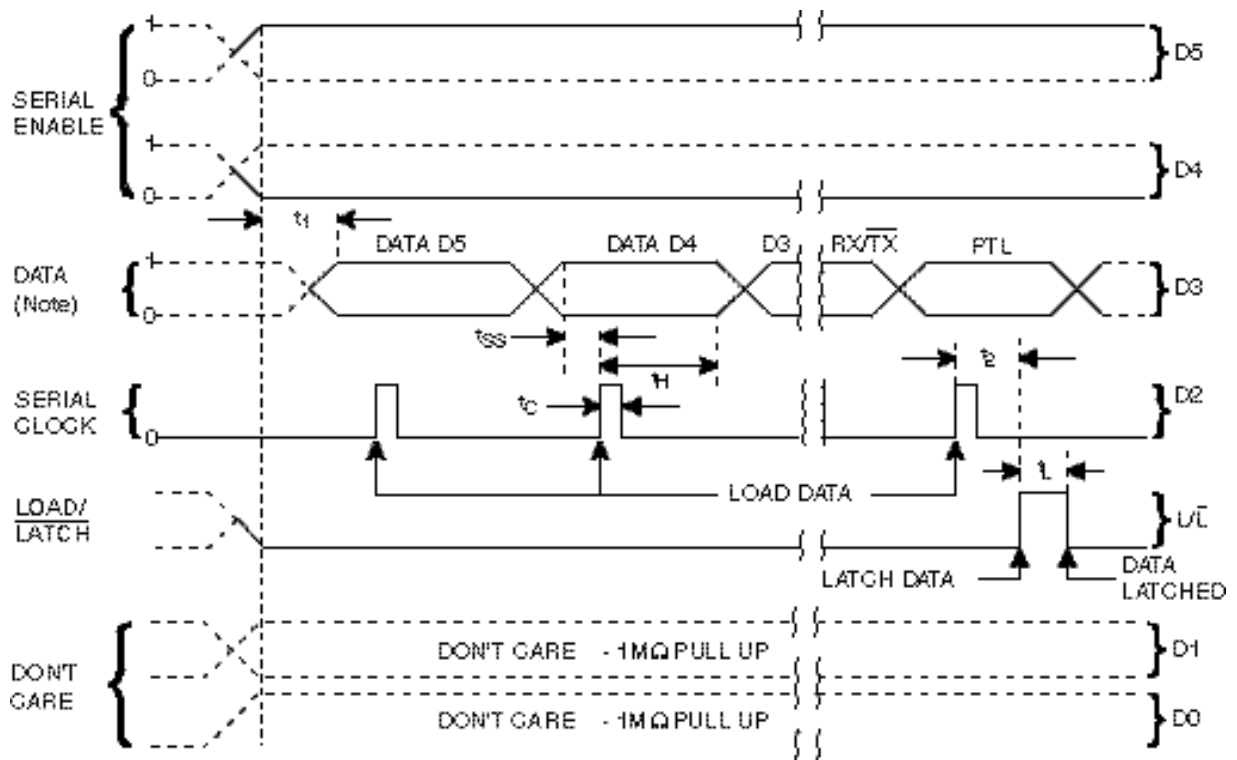

Figure 4 : Parallel Mode



Note : Serial bit 1 through bit 8 = D5, D4, D3, D2, D1, D0, RX/TX and PTL respectively. Load bit 1 first, bit 8 last

Figure 5 : Serial Mode

4.5 CTCSS Programming

	Tone			Programming Inputs						
	Nominal Frequency (Hz)	MX465 Frequency (Hz)	Δf_0 (%)	D5	D4	D3	D2	D1	D0	Hex
	67.0	66.98	-0.029	1	1	1	1	1	1	3F
	69.3	69.32	0.024	1	1	1	0	0	1	39
	71.9	71.901	0.001	0	1	1	1	1	1	1F
	74.4	74.431	0.042	1	1	1	1	1	0	3E
	77.0	76.965	-0.046	0	0	1	1	1	1	0F
	79.7	79.677	-0.029	1	1	1	1	0	1	3D
	82.5	82.483	-0.021	0	1	1	1	1	0	1E
	85.4	85.383	-0.020	1	1	1	1	0	0	3C
	88.5	88.494	-0.007	0	0	1	1	1	0	0E
	91.5	91.456	-0.048	1	1	1	0	1	1	3B
	94.8	94.76	-0.042	0	1	1	1	0	1	1D
	97.4	97.435	-0.036	1	1	1	0	1	0	3A
	100.0	99.96	-0.040	0	0	1	1	0	1	0D
	103.5	103.429	-0.069	0	1	1	1	0	0	1C
	107.2	107.147	-0.05	0	0	1	1	0	0	0C
	110.9	110.954	0.049	0	1	1	0	1	1	1B
	114.8	114.84	0.035	0	0	1	0	1	1	0B
	118.8	118.793	-0.006	0	1	1	0	1	0	1A
	123.0	123.028	0.023	0	0	1	0	1	0	0A
	127.3	127.328	0.022	0	1	1	0	0	1	19
	131.8	131.674	-0.095	0	0	1	0	0	1	09
	136.5	136.612	0.082	0	1	1	0	0	0	18
	141.3	141.323	0.016	0	0	1	0	0	0	08
	146.2	146.044	-0.107	0	1	0	1	1	1	17
	151.4	151.441	0.027	0	0	0	1	1	1	07
	156.7	156.875	0.112	0	1	0	1	1	0	16
•	159.8	159.936	0.085	1	1	0	0	0	1	31
	162.2	162.311	0.069	0	0	0	1	1	0	06
	167.9	167.708	-0.114	0	1	0	1	0	1	15
	173.8	173.936	0.078	0	0	0	1	0	1	05
	179.9	179.654	-0.137	0	1	0	1	0	0	14
•	183.5	183.680	0.098	1	1	0	0	1	0	32
	186.2	186.289	0.048	0	0	0	1	0	0	04
•	189.9	190.069	0.089	1	1	0	0	1	1	33
	192.8	192.864	0.033	0	1	0	0	1	1	13
•	196.6	196.329	-0.138	1	1	0	1	0	0	34
•	199.5	199.312	-0.094	1	1	0	1	0	1	35
	203.5	203.645	0.071	0	0	0	0	1	1	03

	Tone			Programming Inputs						
	Nominal Frequency (Hz)	MX465 Frequency (Hz)	Δf_0 (%)	D5	D4	D3	D2	D1	D0	Hex
•	206.5	206.207	-0.142	1	1	0	1	1	0	36
	210.7	210.848	0.070	0	1	0	0	1	0	12
	218.1	217.853	-0.113	0	0	0	0	1	0	02
	225.7	225.339	-0.160	0	1	0	0	0	1	11
•	229.1	229.279	0.078	1	1	0	1	1	1	37
	233.6	233.359	-0.103	0	0	0	0	0	1	01
	241.8	241.970	0.070	0	1	0	0	0	0	10
	250.3	250.282	-0.007	0	0	0	0	0	0	00
•	254.1	254.162	0.024	1	1	1	0	0	0	38
	Notone		N/A	1	1	0	0	0	0	30
	Serial input mode		N/A	1	0	Data	Clock	X	X	2X
• Not specified in the TIA/EIA tone set										

Table 4: CTCSS Tones

5 Performance Specification

5.1 Electrical Performance

5.1.1 Absolute Maximum Ratings

Exceeding these maximum ratings can result in damage to the device. Operation of the device outside the operating limits is not implied.

General	Min.	Max.	Units
Supply ($V_{DD} - V_{SS}$)	-0.3	7.0	V
Voltage on any pin to V_{SS}	-0.3	$V_{DD} + 0.3$	V
Current			
V_{DD}	-30	30	mA
V_{SS}	-30	30	mA
any other pins	-20	20	mA
TN / DW / DIP Package			
Total Allowable Power Dissipation at $T_{AMB} = 25^\circ\text{C}$		800	mW
Derating above 25°C		10	mW/ $^\circ\text{C}$ above 25°C
Storage Temperature	-55	125	$^\circ\text{C}$
Operating temperature	- 40	85	$^\circ\text{C}$
DS Package			
Total Allowable Power Dissipation at $T_{AMB} = 25^\circ\text{C}$		550	mW
Derating above 25°C		9	mW/ $^\circ\text{C}$ above 25°C
Storage Temperature	-55	125	$^\circ\text{C}$
Operating temperature	- 40	85	$^\circ\text{C}$

5.1.2 Operating Limits

Correct operation of the device outside these limits is not implied.

	Min.	Max.	Units
Supply ($V_{DD}-V_{SS}$)	2.7	5.5	V
Xtal Frequency	4.0	4.0	MHz
Operating Temperature	-40	85	°C

5.1.3 Operating Characteristics

For the following conditions unless otherwise specified:

$V_{DD} = 3.3V / 5.0V$ at $T_{AMB} = 25^{\circ}C$, $V_{SS} = 0V$,

Xtal Frequency = 4.0 MHz, 100ppm max.

(Over the life of the XTAL the operating range may vary from 100ppm up to 1000ppm)

0dB ref. = 750mV_{RMS} (proportional to V_{DD} ; see note 17)

Composite Signal:

1kHz test tone = 300mV_{RMS}, f0 CTCSS tone = 30 mV_{RMS}, 75mV_{RMS} Noise (band limited to 6kHz Gaussian)

	Notes	Min.	Typ.	Max.	Units
Static Values					
Supply voltage		2.7	3.3/5.0	5.5	V
Supply current					
$V_{DD} = 5.0V$			3.7	4.2	mA
$V_{DD} = 3.3V$			1.3	1.6	mA
Analog input impedance	18	480	550		k Ω
Analog output impedance	18		400	1000	Ω
Digital Input impedance	1,18	25	40		k Ω
Input logic 1	1	70% V_{DD}			V
Input logic 0	1			30% V_{DD}	V
Output Logic 1 source = 0.1mA	2	80% V_{DD}			V
Output Logic 0 sink = 0.1mA	2			20% V_{DD}	V
Dynamic Values					
Speech filter					
Total harmonic distortion	5,8,19		1.0	1.5	%
Output noise level (input AC short circuit, audio switch enabled)	8,18		0.5	1.0	mV _{RMS}
Sinad	8,9	40	50		dB
Spurious emissions	18			- 48	dB
Cutoff frequency			300		Hz
Bandpass ripple	8		1	1.8	dB
Stopband attenuation <250Hz	7,8,19	33	36		dB
Passband gain 1kHz		- 0.5	0	0.5	dB
TX/RX isolation	5		60		dB

	Notes	Min.	Typ.	Max.	Units
Encoder					
Tone output level	12	- 1.0	0	1.0	dB
Tone Frequency Accuracy (f error)		- 0.3		0.3	%f ₀
Risetime to 90% nominal output					
f ₀ >100Hz	4,10		15	75	ms
f ₀ <100Hz	4,10		45	120	ms
Total Harmonic Distortion	19		1.5	2	%
Decoder					
Pure tone decode threshold	19		7	15	mV _{RMS}
Composite signal decode threshold	3			30	mV _{RMS}
Decode input signal level	16	-20		3.5	dB
Pure tone decode response time	13,14	95	115	140	ms
Pure tone decode deresponse time	13,15	95	130	170	ms
Decode response time	3,6,10			250	ms
Deresponse time	3,10		180	250	ms
Decode selectivity:					
Upper decode band edge	3,11,19,20	1.005f ₀	1.015f ₀	0.995f ₀₊₁	Hz
Lower decode band edge	3,11,19,20	1.005f ₀₋₁	0.985f ₀	0.995f ₀	Hz
Serial / Parallel Inputs					
Parallel Set Up Time (t _{SP})		400			ns
Load / Latch Pulse Width (t _L)		400			ns
Serial Clock Pulse Width (t _C)		400			ns
Serial Data Set-Up Time (t _{SS})		400			ns
Serial Data Hold Time (t _H)		400			ns
Serial Enable Time (t ₁)		400			ns
Serial Load / Latch Set-Up Time (t ₂)		400			ns
Serial Clock Frequency			1		MHz

Operating Characteristics Notes:

1. Refers to RX/TX, PTL, Decode Comparator Input, D0-D5.
2. All logic outputs.
3. Composite signal test condition.
4. Any programming tone and R_L = 10kΩ, C_L = 15pF.
5. With an input level of 0dB @1kHz
6. f₀>100Hz (for 100 Hz> f₀>67Hz: t=100/ f₀Hz x 250ms)
7. See Figure 3.
8. Measured in a 30kHz bandwidth.
9. With an input level of -3.5dB @1kHz
10. Per TIA/EIA-603.
11. Per TIA/EIA-603, device will not decode adjacent TIA/EIA-603 Tones.
12. Tone output level is proportional to V_{DD}.
13. f₀=156.7Hz @ -20dB.
14. Typically 12.5 Tone Cycles + 40ms.

15. Typically 7 Tone Cycles + 90ms.
16. Max composite signal is 3.5dB with:
 Noise (band limited 6kHz Gaussian) = -12dB ref to 1kHz test tone
 f_0 CTCSS tone = -20dB ref to 1kHz test tone
17. For maximum dynamic range, set audio level to 0dB, $V_{DD} \times 150mV_{RMS}$, using minimum V_{DD} under which system is intended to work. (e.g. for a 2.7V system, use 0dB equal to $405mV_{RMS}$).
18. By characterization only.
19. Batch sampled only
20. For example, if: $f_0 = 100.0Hz$ ($f_{0-1} = 97.4Hz$ $f_{0+1} = 103.5Hz$)

Decode Selectivity	Min	Typ	Max	Unit
Upper Decode Band Edge	100.5	101.5	102.98	Hz
Lower Decode Band Edge	97.89	98.5	99.5	Hz

5.2 Packaging

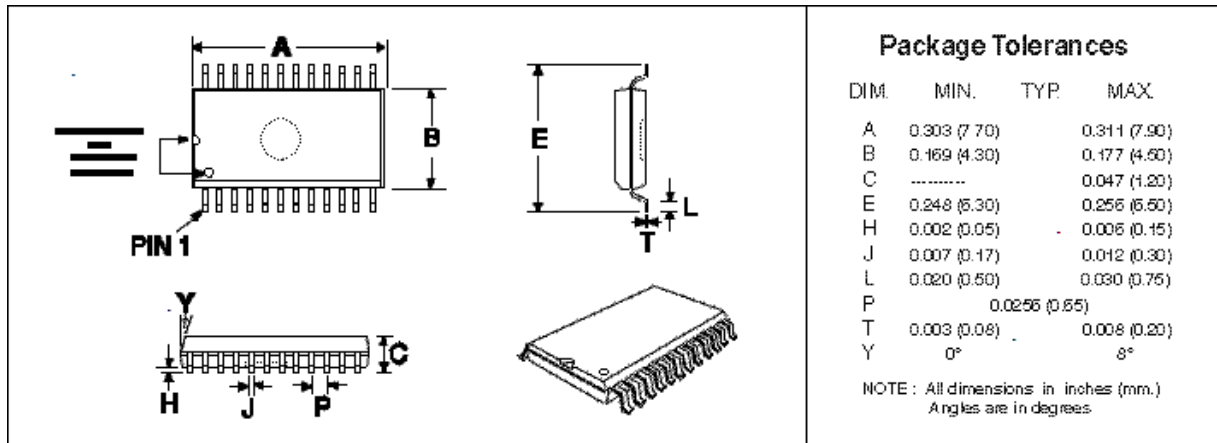

Figure 6: 24-pin TSSOP Mechanical Outline: Order as part no. MX465TN

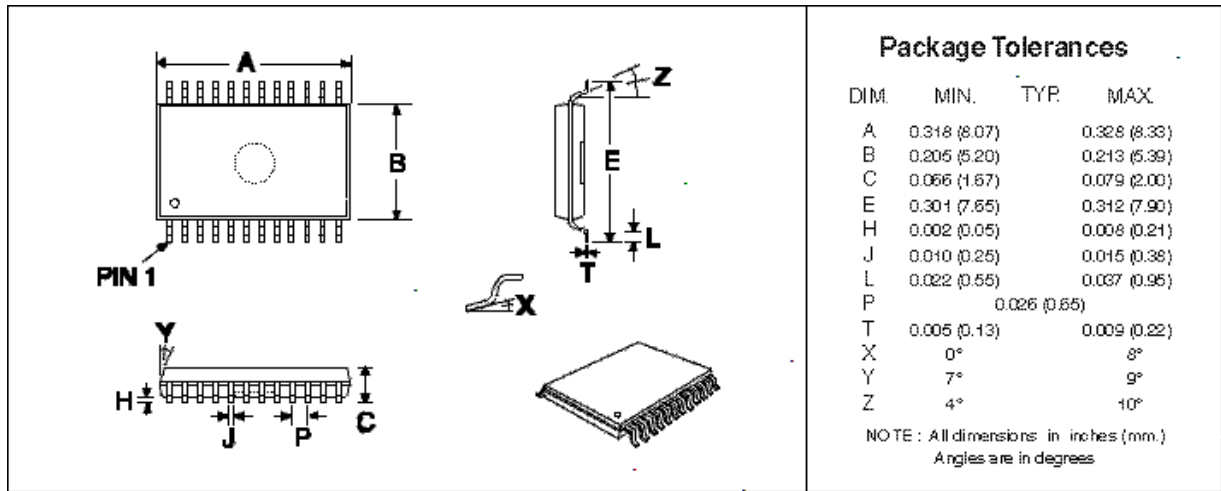

Figure 7: 24-pin-SSOP Mechanical Outline: Order as part no. MX465DS

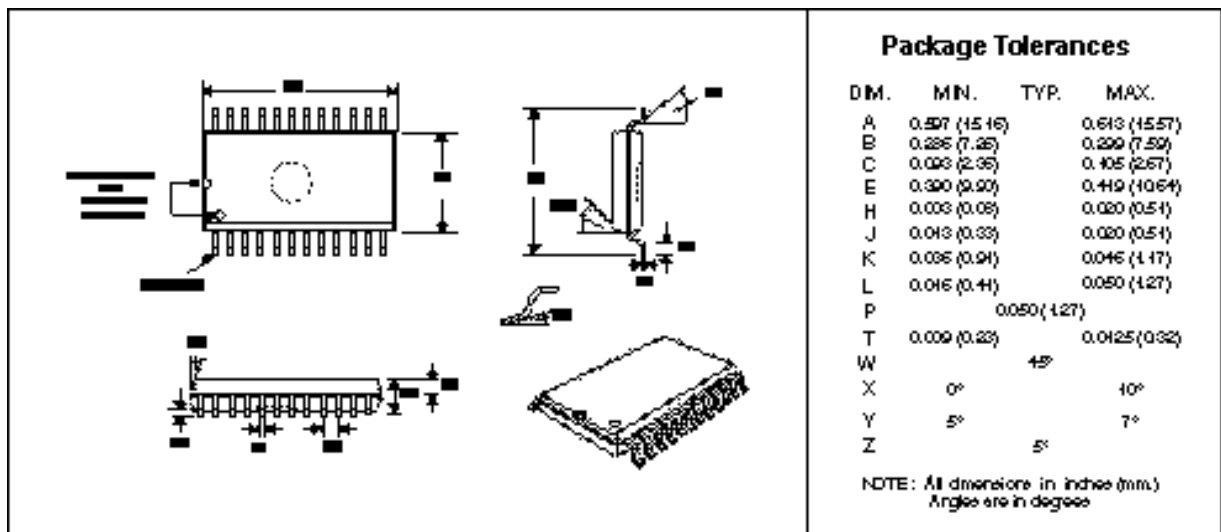

Figure 8: 24-pin SOIC Mechanical Outline: Order as part no. MX465DW

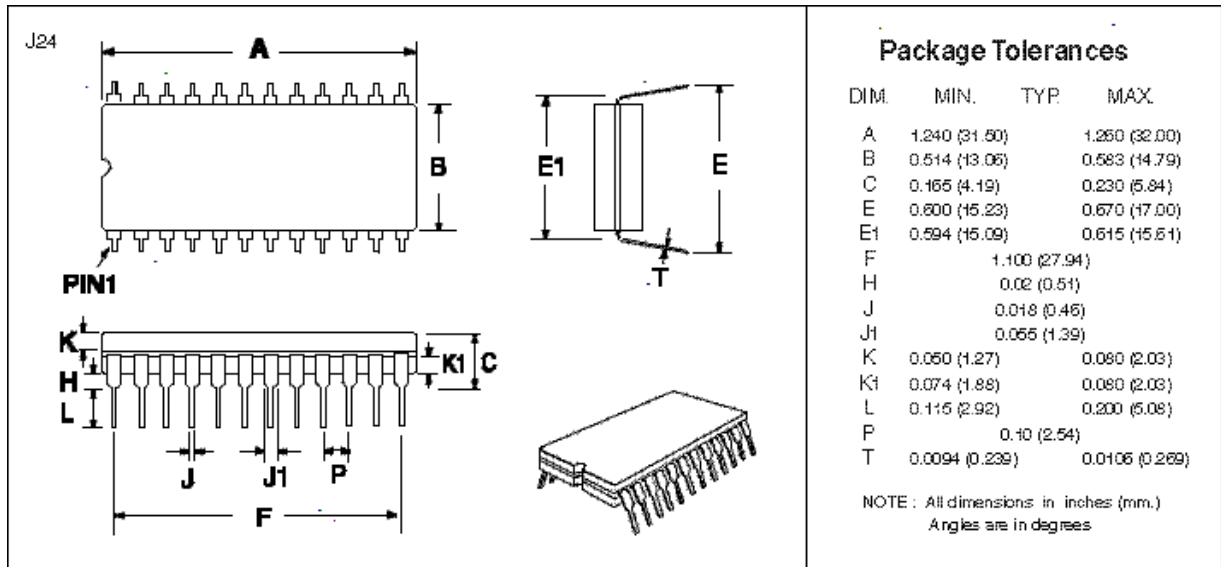

Figure 9: 24-pin CDIP Mechanical Outline: Order as part no. MX465J

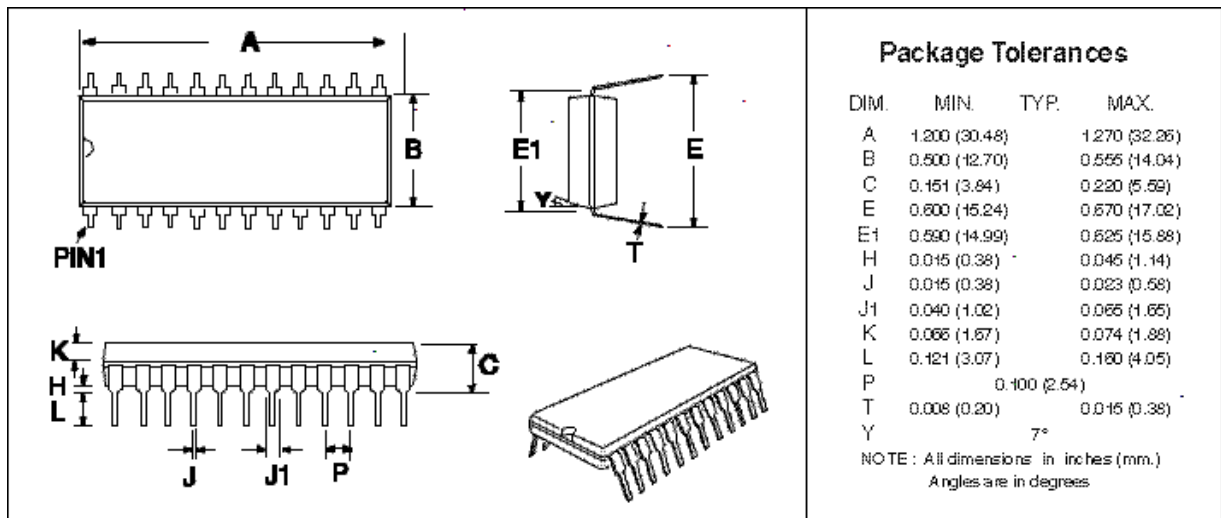

Figure 10: 24-pin PDIP Mechanical Outline: Order as part no. MX465P