

TA7245BP/BP(LB)/CP/F

DC MOTOR DRIVER IC.

The TA7245BP/CP are 3-phase Bi-directional motor driver IC.

It is designed for use VTR, tape deck, floppy disk and record player motor drivers. It contains output power drivers, position sensing circuits, control amplifier and CW/CCW control circuit.

- . 3-Phase Bi-Directional Driver and Output Current Up to $\pm 1.2A$.
- . Few External Parts Required.
- . Wide Operating Supply Voltage Range : $V_{CC(opr)}(MIN.)=7V$
- . Forward and Reverse Rotation is Controlled Simply by Means of a CW/CCW Control Signal Fed Into 10 PIN.
- . High Sensitivity of Position Sensing Amplifier.
($V_H=10mV(Typ.)$, Recommend to Use TOSHIBA Ga-As Hall Sensor "THS" Series.)
- . Surge Protect Diode Connected for All Input Terminals.
(Position Sensing, Control, CW/CCW Control Inputs.)
- . DIP-14F (TOSHIBA 5D14BP-P) Power Package.

MAXIMUM RATINGS (Ta=25°C)

CHARACTERISTIC		SYMBOL	RATING	UNIT
Supply Voltage	TA7245BP	V _{CC}	26	V
	TA7245CP		30	
	TA7245BP(LB)		26	
	TA7245F		26	
Output Current		I _{O(AVE)}	1.2	A
Power Dissipation (Note)	TA7245BP	P _D	2.3	W
	TA7245CP		2.3	
	TA7245BP(LB)		2.3	
	TA7245F		1.0	
Operating Temperature		T _{opr}	-30 ~ 75	°C
Storage Temperature		T _{stg}	-55 ~ 150	°C

Note : Ta=25°C. Without heat sink

TA7245BP/BP(LB)/CP/F

<p>Package width and length do not include mold protrusion. Allowable mold protrusion is 0.15mm.</p>	<p>Package width and length do not include mold protrusion. Allowable mold protrusion is 0.15mm.</p>
<p>JEDEC -</p>	<p>JEDEC -</p>
<p>TOSHIBA HDIP14-P-500A</p>	<p>TOSHIBA HDIP14-P-500</p>
<p>Package width and length do not include mold protrusion. Allowable mold protrusion is 0.15mm.</p>	<p>Package width and length do not include mold protrusion. Allowable mold protrusion is 0.15mm.</p>
<p>JEDEC -</p>	<p>JEDEC -</p>
<p>TOSHIBA HSOP14-P</p>	<p>TOSHIBA HSOP20-P-450</p>

TA7245BP/BP(LB)/CP/F

BLOCK DIAGRAM

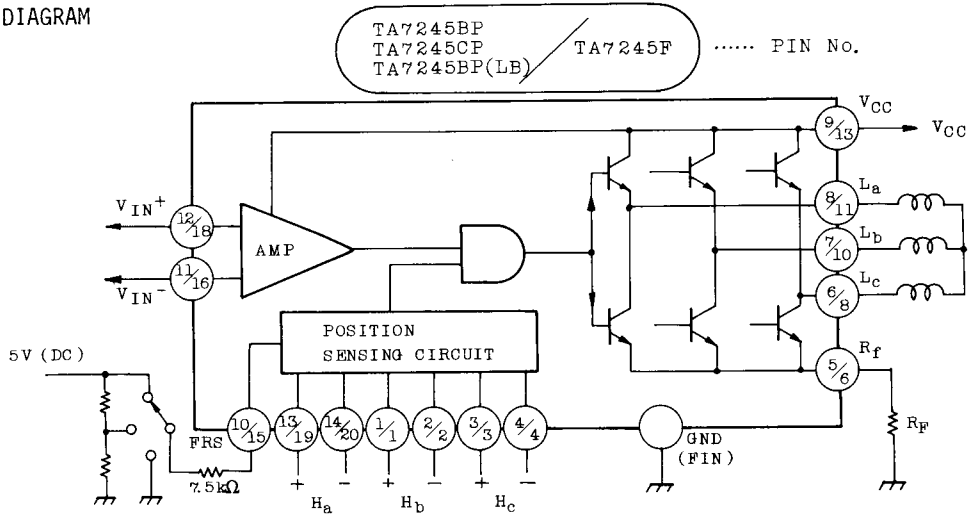

ELECTRICAL CHARACTERISTICS (Unless otherwise specified, $V_{CC}=12V$, $T_a=25^\circ C$)

CHARACTERISTIC	SYMBOL	TEST CIRCUIT	TEST CONDITION	MIN.	TYP.	MAX.	UNIT
Quiescent Current	I_{CC1}	-	FRS Open	2	4	7	mA
	I_{CC2}	-	FRS=5V	2	5	9	
	I_{CC3}	-	$V_{CC}=22V$, FRS=GND	2	5	9	
Input Offset Voltage	V_{IO}	-		-	40	-	mV
Residual Output Voltage	V_{OR}	-	$V_{IN}^+ = V_{IN}^- = 7V$	-	0	10	mV
Voltage Gain	G_v	-		-	5.5	-	
Saturation Voltage	Upper	V_{SAT1}	$I_L=400mA$	-	1.0	1.5	V
	Lower	V_{SAT2}		-	0.4	1.0	
Cut-off Current	Upper	I_{OC1}	$V_{CC}=20V$	-	-	20	μA
	Lower	I_{OC2}		-	-	20	
Position Sensing Input Sensitivity	V_H	-		-	10	-	mV
Maximum Position Sensing Input Voltage	$V_H \text{ MAX}$	-		-	-	400	mV
Input Operating Voltage	Position	CMR-H	-	2.0	-	$V_{CC}-2.5$	V
	Control	CMR-C	-	2.0	-	$V_{CC}-2.5$	
Rotation Control Input Voltage	CW	V_F	-	-	0	0.4	V
	STOP	V_S	-	2.2	2.7	3.2	
	CCW	V_R	-	4.8	5.0	5.8	

TA7245BP/BP(LB)/CP/F

TEST CIRCUIT 1

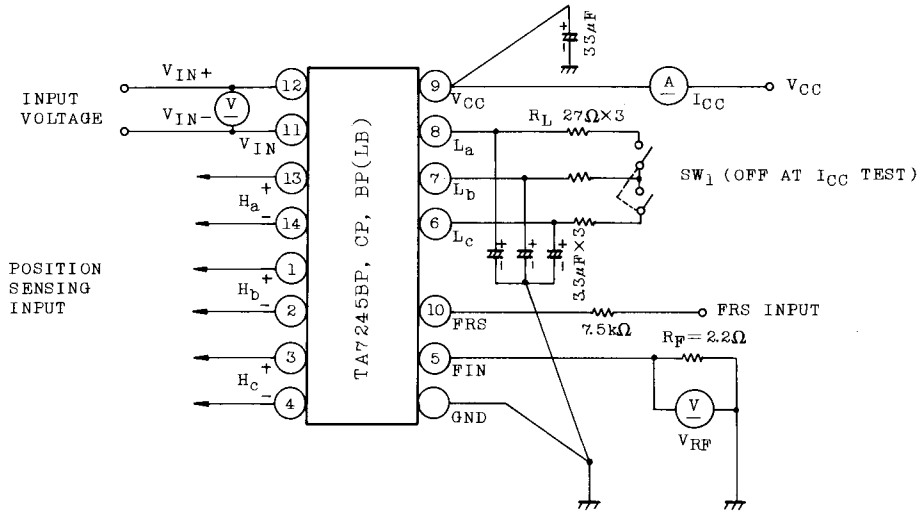

TEST CIRCUIT 2

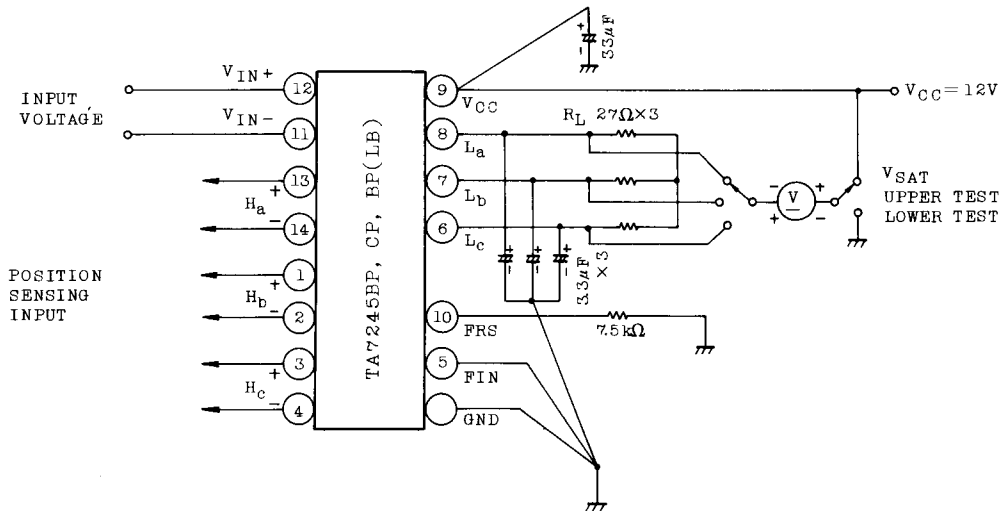

INPUT/OUTPUT CHARACTERISTICS

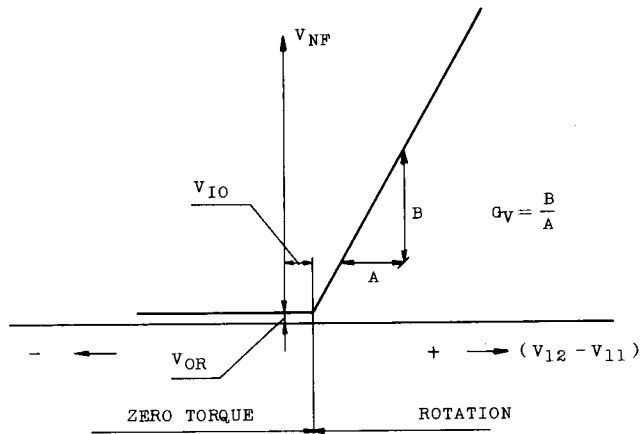

V_{NF} shows voltage drop at R_F .

That is, in the case of star connection, when coil current is I_L'

$$V_{NF} = R_F \cdot I_L$$

See the following circuit.

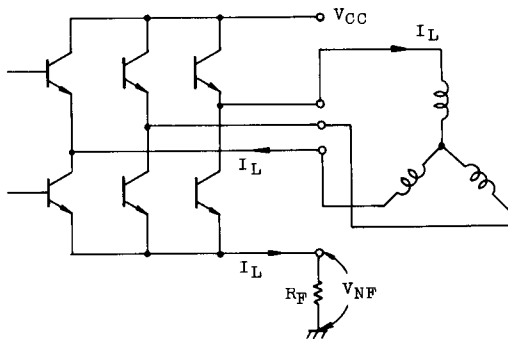

Further, if inputs (11 pin, 12 pin) are shorted or $V_{11} \geq V_{12}$, torque at the circuit becomes zero. However, this zero torque state also can be obtained by setting FRS input (10 pin) to specified voltage or by placing the circuit in open state and this is rather advantageous as current consumption is less.

TA7245BP/BP(LB)/CP/F

FUNCTION

FRS (CW/CCW/STOP) INPUT	POSITION SENSING INPUT			OUTPUT		
	H _a	H _b	H _c	L _a	L _b	L _c
L	1	0	1	H	L	M
	1	0	0	H	M	L
	1	1	0	M	H	L
	0	1	0	L	H	M
	0	1	1	L	M	H
	0	0	1	M	L	H
H	1	0	1	L	H	M
	1	0	0	L	M	H
	1	1	0	M	L	H
	0	1	0	H	L	M
	0	1	1	H	M	L
	0	0	1	M	H	L
M	1	0	1	High Impedance		
	1	0	0			
	1	1	0			
	0	1	0			
	0	1	1			
	0	0	1			

Note: "1" of the hole element input means that voltage above +10mV is applied to the positive side of each hall element from the negative side and "0" means that voltage above +10mV is applied to the negative side from the positive side.

In this case, needless to say, DC potential must be within the specified common mode voltage range of hall element input.

Further, "H", "M" and "L" of output mean $V_{CC}-V_{SAT1}=1/2 V_{CC}$ and V_{SAT2} , respectively, and "L", "H" and "M" of FRS input mean application of voltage within specified values of V_F , V_R and V_S , respectively.

Further, by applying required voltage for control input (V_{IN+} , V_{IN-}), measure the circuit in operating state.

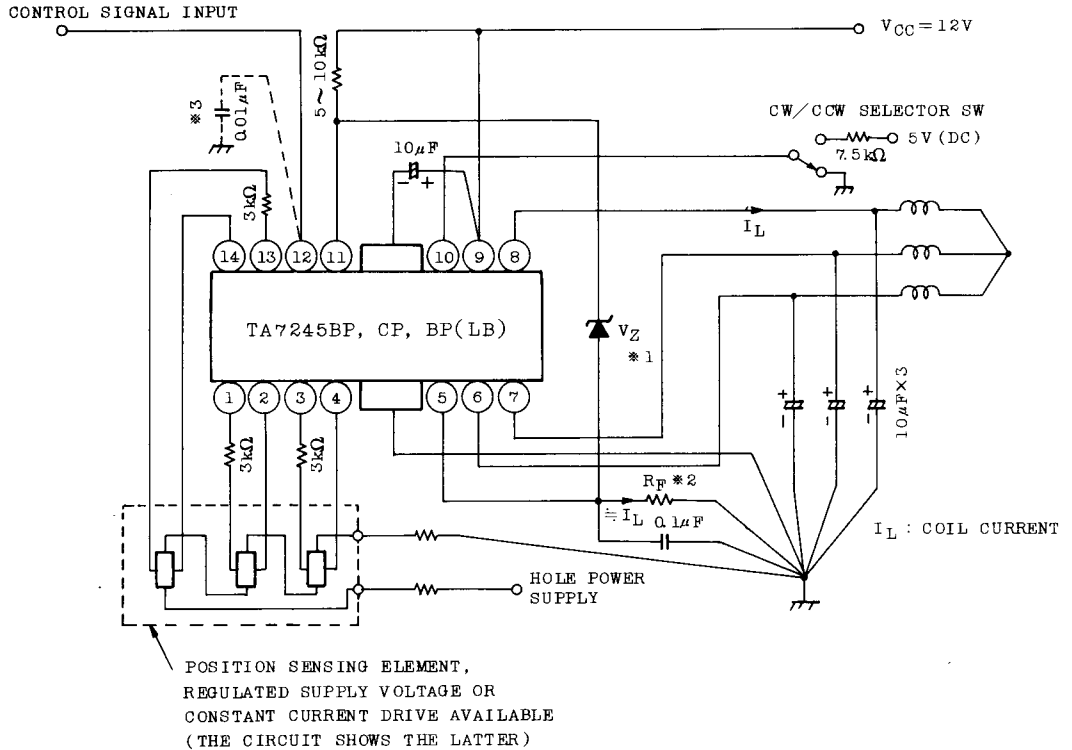
TA7245BP APPLICATION CIRCUIT 1

- * 1 V_Z of a ZENER diode should be decided in accordance with the DC level of control signal input. ($V_Z = 2.5 \sim 9V$. If temperature characteristic is to be taken into consideration, 5V is recommended. Further, DC potential at the negative control input 11 pin becomes $V_Z + R_F \cdot I_L$)
- * 2 As to R_F , although it should be decided according to coil impedance, F/V converted voltage (control input) and required starting torque, it is recommended to set at $0.3 \sim 5\Omega$.
- * 3 Connect, if required.

TA7245BP/BP(LB)/CP/F

APPLICATION CIRCUIT 2

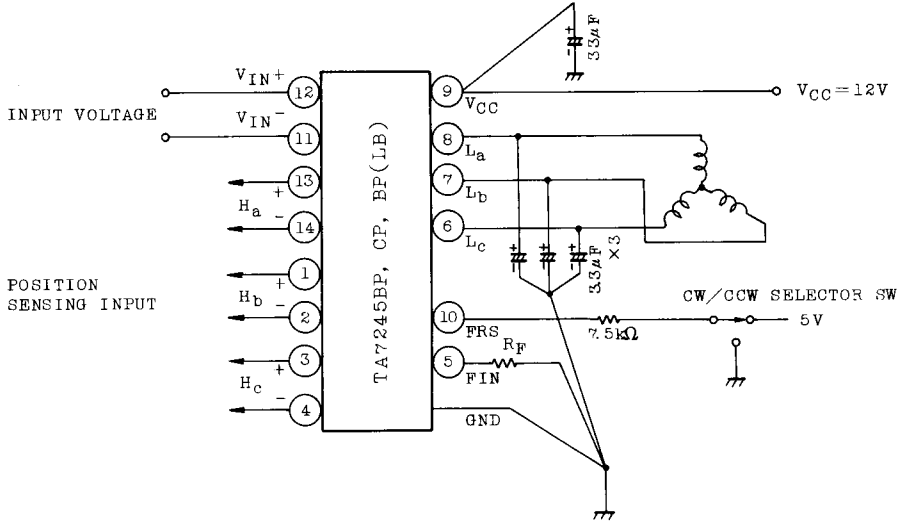

$P_D - T_a$ TA7245BP, CP, BP(LB)

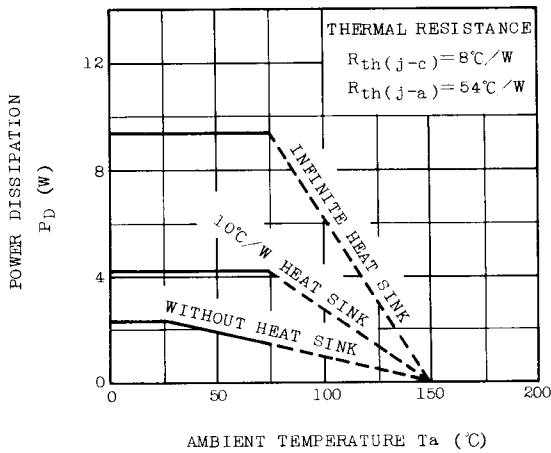

$P_D - T_a$ TA7245F

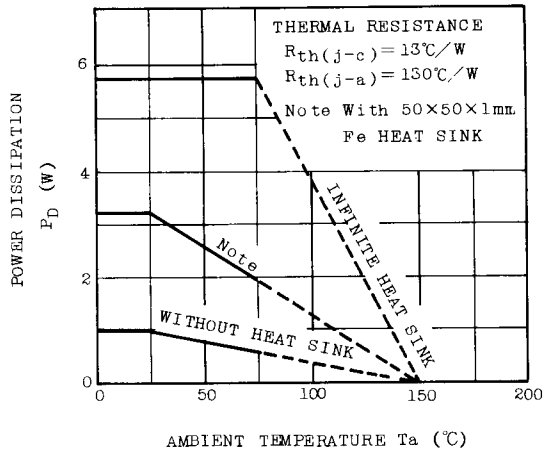

CONTROL SIGNAL INPUT METHOD

Normally, control voltage which is proportional to (or inversely proportional to) rotation speed (F/V converter etc.) is fed into the front stage of the TA7245BP differentially or single polarity. The gain from control input of the TA7245BP to output (at R_F terminal) is 5.5 times as indicated in the specification. It is however possible to improve characteristic of W/F, etc. by reducing the gain with NF applied.

It's application example is shown in the diagram below. Further, when NF is applied (Also, when not applied), it is necessary that DC voltages (V₁₁, V₁₂) of control inputs (11 pin, 12 pin) are within the range of values (2.0~V_{CC}-2.5V) shown in the standard. In addition, when input DC level and F/V converted output (control output) cannot be matched with IC input, a DC level shift diode and attenuator should be inserted in front of IC input. An example is shown in Fig. 1-c.

a) IN CASE OF POSITIVE INPUT

$$(N \propto \frac{1}{V_{cont}})$$

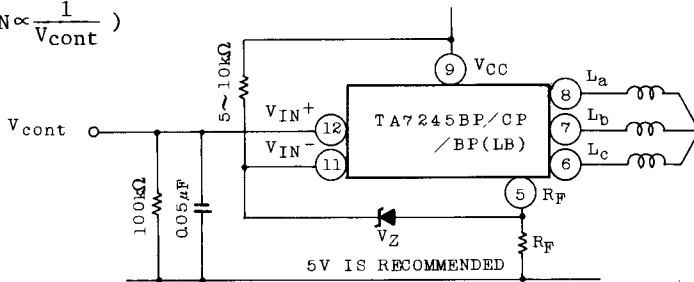

Fig. 1-a

$$V_{11} \cong V_Z$$

$$V_{12} \cong V_{cont}$$

b) IN CASE OF NEGATIVE INPUT

$$(N \propto V_{cont})$$

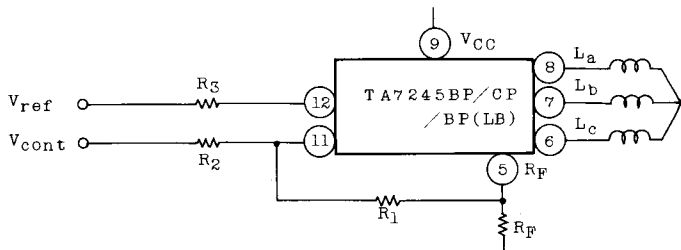
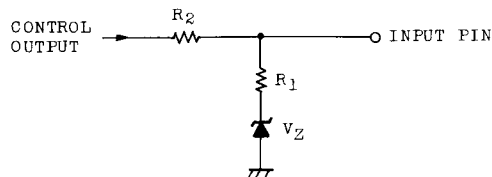

Fig. 1-b

$$V_{12} \cong \frac{R_1 R_2}{R_1 + R_2}$$

$$V_{12} \cong V_{ref}$$

$$V_{11} \cong V_{cont} \cdot \frac{R_1}{R_1 + R_2}$$



DC level of control output is shifted by a zener diode and control signal output is attenuated by R₁ and R₂.

Fig. 1-c

TA7245BP/BP(LB)/CP/F

POSITION SENSING ELEMENT DRIVING METHOD

The TA7245BP has a wide range of common mode voltage range (the specification is 2 to $V_{CC}-2.5V$ and therefore, 2 to 9.5V when $V_{CC}=12V$) of the position sensing element (generally, a hall sensor) input and therefore, both the constant current drive and constant voltage drive of a hall sensor are applicable.

As a hall sensor, Toshiba Ga-As hall sensor THS series are recommended.

When compared with In-Sb hall sensor, the Ga-As hall sensor has various merits such as excellent mechanical strengths, temperature stability and less saturation characteristic to magnetism and current.

However, it is considered that use of this sensor was so far difficult as it's sensitivity is lower than In-Sb hall sensor. On the TA7245BP in order to make it possible to use the Ga-As hall sensor which has merits on almost all items except sensitivity, sensitivity of the position sensing amplifier has been increased with less offset voltage. Further, if W/F characteristic is poor, increase of hall input may be effective in some cases. (However, be careful not to exceed max. allowable input).

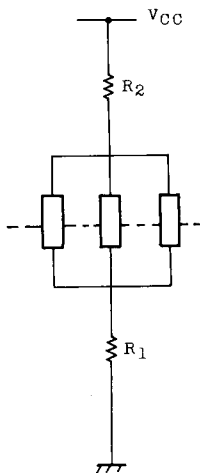

POSITION SENSING ELEMENT
DRIVING METHOD (1)

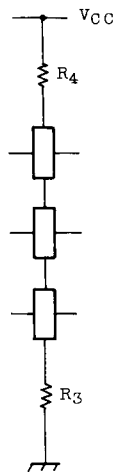

(2)

(For details refer to the technical data for Toshiba Ga-As hall sensor THS series.)

CAUTIONS IN APPLICATION

IC for motor drive have several high impedance input terminals such as hall element input, control signal input, etc. and to handle a switched high output current. Because of such a reason. Care should be taken not to make a parasitic oscillation path caused by unnecessary feedback.

Further, as load is a coil, it is necessary to pay attention to prevent destruction by impulse at time of ON/OFF, particularly, application of voltage and current in excess of standard values to the output transistor when supply voltage is at high level ($V_{CC}=18V$ or above). It is recommended to use the TA7245BP at supply voltage below 12V and the TA7245CP at below 18V. If they are used supply voltage above these values, the above-mentioned cautions should be followed.

(1) CAUTIONS FOR RELIABILITY DESIGN

- a) Do not into the output transistor inside IC into the high voltage and current operating region.
(Especially, when a motor is locked, V_{CC} is ON/OFF, output is shorted, etc.)
- b) It is desirable to design the output ringing absorbing capacitor in capacitance as small as possible (the output transistor may be destructed by charging/dis-charging current of this capacitor in some cases).
If it becomes a problem, it is recommended to review not only capacitance but also connecting point and connecting method (delta or star connection) in addition to taken an oscillation preventing measure described later furthermore, to insert resistor (3Ω to 30Ω) in series to the capacitor.
- c) In installing to a printed circuit board, be careful not to apply an abnormal force to the fin of IC and moreover, to solder in several seconds (at $260^{\circ}C$).
- d) It is an effective method for assuring reliability to provide a large earthing area on a printed circuit board to promote heat-radiation from the soldered fin of IC.

(2) CAUTIONS FOR WIRING

It is recommend to design a print pattern with the following methods taken into consideration in order to prevent parasitic oscillation.

TA7245BP/BP(LB)/CP/F

- a) The output coil current path line should be provided separately from other earth one because the coil current includes switched high current. In particular, it is recommended to design a line from R_F terminal (5 pin) to the earth so that it's impedance does not become common to other circuits. (This is especially important.)
- If this is not possible or oscillation cannot be eliminated completely, it is advised to connect a capacitor of $0.001 \sim 0.1 \mu F$ parallelly with R_F .

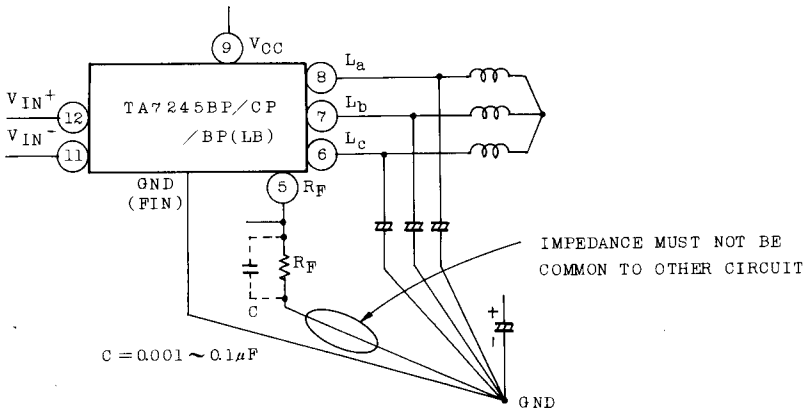

Fig. 2

- b) It is also recommended to provide the hall element drive current path independently. (Especially, separately from the output current path) Further, if plunging input to the position sensing element is expected, it is advised to insert a capacitor of $0.05 \sim 1 \mu F$ between the plus (+) and minus (-) terminals of each position sensing input.

In addition, it should be also consider to insert resistors in series to all hall element inputs. If plunging input to control input is expected, connect a capacitor of $0.001 \sim 0.1 \mu F$ between control terminal and GND.

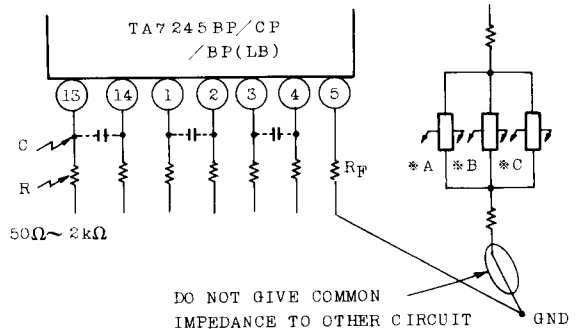

Fig. 3

- c) If parasitic oscillation in a high frequency range above 5MHz is observed, commonly connect the capacitors from all coil outputs and connect a capacitor ($C=0.01\sim 0.1\mu\text{F}$) to R_F terminal (5 pin) from this connecting point (Fig. 4-a). Further, it is also recommended to consider a method to connect capacitors to R_F terminal from respective coil outputs separately from the ringing absorbing capacitor (Fig. 4-b).

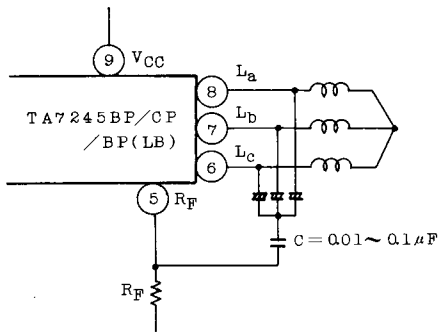

Fig. 4-a

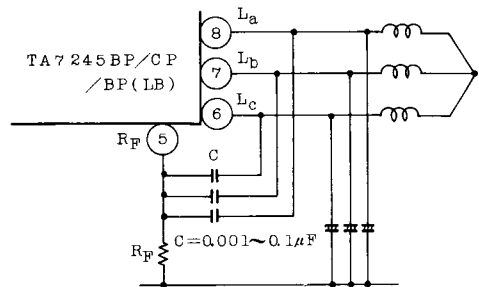

Fig. 4-b

- d) It is recommended to connect a path capacitor directly from VCC terminal (9 pin) without giving common impedance to GND. Further, it is also effective to insert C_2 ($0.01\sim 0.1\mu\text{F}$).

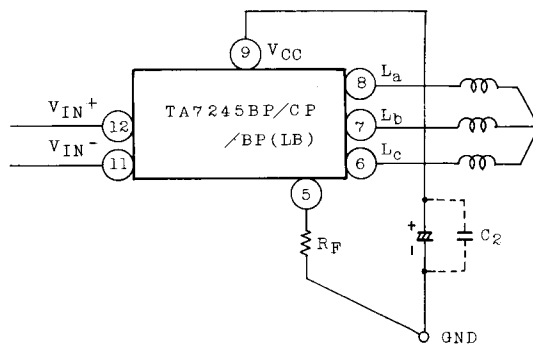

Fig. 5

TA7245BP/BP(LB)/CP/F

(3) CONNECTION OF OUTPUT RINGING ABSORBING CAPACITOR

It is advised to connect the output ringing absorbing capacitor to GND from each coil terminal. In addition, it is also advised to consider the following methods from the viewpoint of parasitic oscillation prevention as well as destruction prevention.

- a) Change of capacitance
- b) Delta connection (Fig. 6-a)
- c) Connection to V_{CC} instead of GND (Fig. 6-b). In this case, however, attention should be paid to destruction. If voltage/current locus is outside ASO, it is necessary to connect resistors in series with capacitors. And propose to connection to R_F terminal.
- d) Connect resistors in series with capacitor (Fig. 6-c).
- e) Combination of a), b), c) and d).

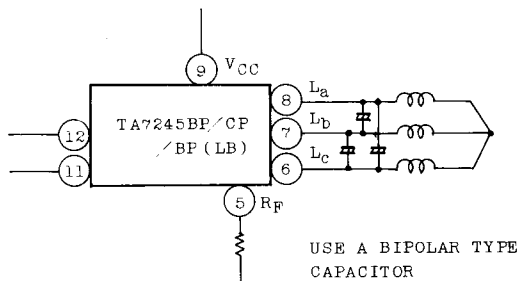

Fig. 6-a

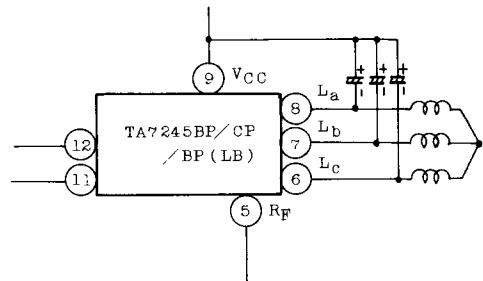

Fig. 6-b

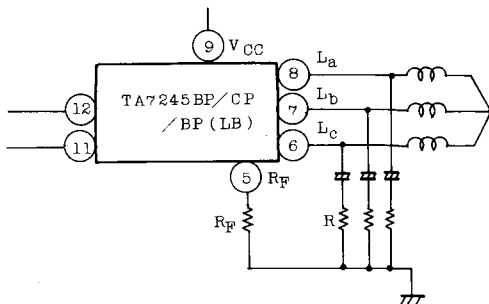

Fig. 6-c

OTHER CAUTIONS

Depending upon capacity and connecting method of the output capacitor, the output transistor inside IC may be destructed in some cases and it is therefore recommended obtain voltage/current locus of the output transistor through the measurement shown below and confirm that the locus is within ASO. (Especially, the measurement at time of SW ON/OFF, CW rotation→CCW rotation→CW rotation is important).

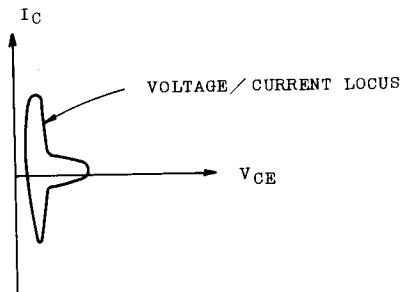
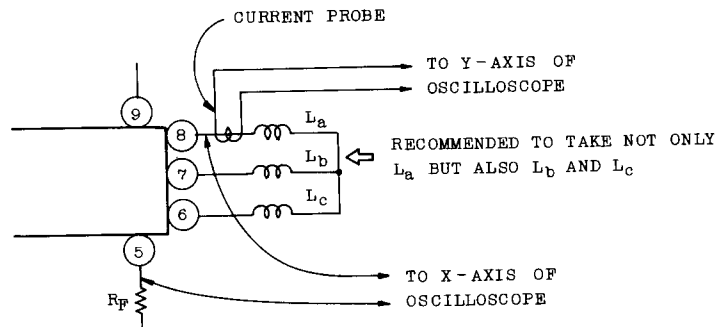

Fig. 7