

GENERAL DESCRIPTION

The CM431A is a three-terminal adjustable shunt voltage regulator with specified thermal stability and pin-to-pin compatible with the earlier 431 series. The output voltage can be adjusted to any value between V_{REF} and 18V by using two external resistors. The CM431A offers low output impedance for improved load regulation with a typical output impedance of 200mΩ. Because of the active output circuitry, the CM431A can replace the zener diodes in applications such as switching power supplies, OVP crowbar circuits, references for A/D, D/A converters with improved turn-on characteristics.

FEATURES

- ◆ Initial voltage reference accuracy of 1.0%.
- ◆ Sink current capability from 1mA to 100mA
- ◆ Typical output dynamic impedance less than 200mΩ;
- ◆ Adjustable output voltage from V_{REF} to 18V
- ◆ Available in SOT-23, SOT-89, TO-92, & SOP-8
- ◆ Low output noise
- ◆ Typical equivalent full range temperature coefficient of 30ppm/°C

APPLICATIONS

- ◆ Voltage Reference
- ◆ Precision shunt regulator
- ◆ High current shunt regulator
- ◆ PWM down converter with reference
- ◆ Voltage monitor

PIN CONFIGURATION

TO-92
Front View

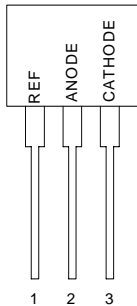

SOT-23-3
Top View

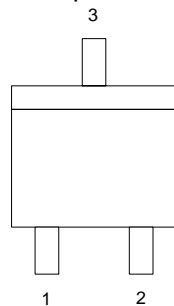

	CM431AXCM233	CM431AXCM2R3
Pin 1	REF	CATHODE
Pin 2	CATHODE	REF
Pin 3	ANODE	ANODE

Suffix "X": Grade "A", "B", "C", "D", or "E"

SOT-23-5
Top View

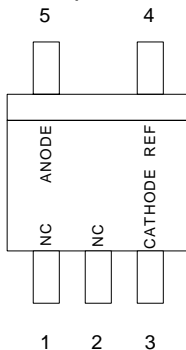

SOT-89
Top View

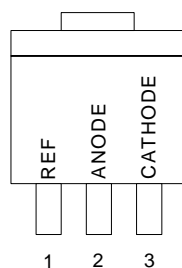

SOP-8
Top View

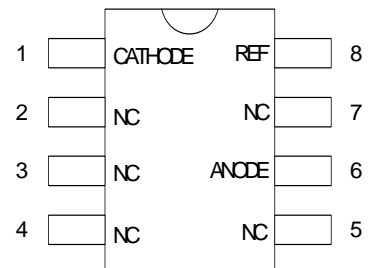

TYPICAL APPLICATION

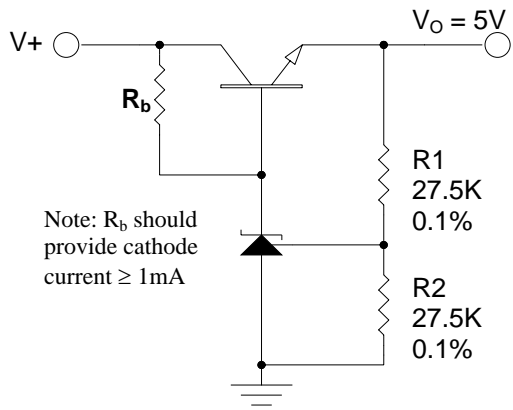

5V Precision Regulator

BLOCK DIAGRAM

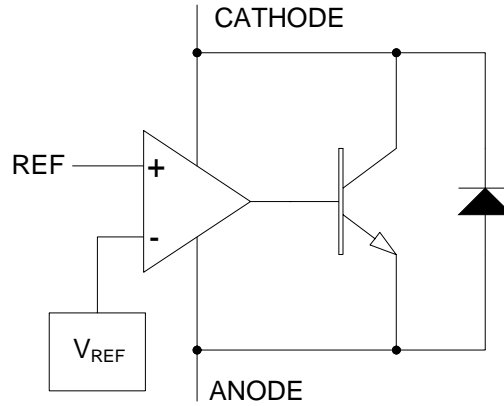



CM431A

LOW VOLTAGE ADJUSTABLE SHUNT REGULATOR

ORDERING INFORMATION

PACKAGE	TOLERANCE			T/R Quantity
	0.5%	1.0%	1.5%	
SOT-23-3 ⁽¹⁾	CM431AACM233	CM431ABCM233	CM431AECM233	TR=3K
SOT-23-3 ⁽¹⁾	CM431AACM2R3	CM431ABCM2R3	CM431AECM2R3	TR=3K
SOT-23-5 ⁽¹⁾	CM431AACM235	CM431ABCM235	CM431AECM235	TR=3K
SOT-89 ⁽¹⁾	CM431AACM89	CM431ABCM89	CM431AECM89	TR=1K
TO-92 ⁽²⁾	CM431AACN	CM431ABCN	CM431AECN	TA=2K
SOP-8	CM431AACS	CM431ABCS	CM431AECS	
SOT-23-3 ⁽¹⁾	CM431AGACM233*	CM431AGBCM233*	CM431AGECM233*	TR=3K
SOT-23-3 ⁽¹⁾	CM431AGACM2R3*	CM431AGBCM2R3*	CM431AGECM2R3*	TR=3K
SOT-23-5 ⁽¹⁾	CM431AGACM235*	CM431AGBCM235*	CM431AGECM235*	TR=3K
SOT-89 ⁽¹⁾	CM431AGACM89*	CM431AGBCM89*	CM431AGECM89*	TR=1K
TO-92 ⁽²⁾	CM431AGACN*	CM431AGBCN*	CM431AGECN*	TA=2K
SOP-8	CM431AGACS*	CM431AGBCS*	CM431AGECS*	

Notes :

- (1) Add suffix "TR" for Tape & Reel.
- (2) Add suffix "TA" for Tape Ammo.
- (3) ***Note:** Add suffix "G" for Pb Free Product

**ABSOLUTE MAXIMUM RATINGS**

Cathode to Anode Voltage (V_{KA}) (Note 2)	-0.3V to 18V
Continuous Cathode Current (I_K)	-100mA to 150mA
Reference Input Current (I_{REF})	-50uA to 10mA
Maximum junction temperature range, T_J	150°C
Storage temperature range	-65°C to 150°C
Lead temperature (soldering, 10 seconds)	260°C
Note 1: Exceeding these ratings could cause damage to the device. All voltages are with respect to Ground. Currents are positive into, negative out of the specified terminal.	
Note 2: Voltage values are with respect to the anode terminal unless otherwise noted.	

POWER DISSIPATION TABLE

Package	θ_{JA} (°C/W)	Derating factor (mW/°C) $T_A \geq 25^\circ\text{C}$	$T_A \leq 25^\circ\text{C}$ Power rating(mW)	$T_A=70^\circ\text{C}$ Power rating(mW)	$T_A= 85^\circ\text{C}$ Power rating (mW)	$T_A= 105^\circ\text{C}$ Power rating (mW)
SOP-8	165	6.06	757	485	394	272
TO-92	156	6.41	801	513	417	288
SOT-89	71(note)	14.1	1763	1128	916	635
SOT-23	285	3.5	438	280	228	158

Note :

- For SOT-89 package, Thermal Resistance-Junction to Tab (θ_{JT}) = 35°C/W. $T_J = T_{TAB} + (P_D \times \theta_{JT})$
- θ_{JA} : Thermal Resistance-Junction to Ambient
Junction Temperature Calculation: $T_J = T_A + (P_D \times \theta_{JA})$.
The θ_{JA} numbers are guidelines for the thermal performance of the device/PC-board system.
All of the above assume no ambient airflow.

RECOMMENDED OPERATING CONDITIONS

	Min	Max	Units
Operating free air temperature range, T_A	0	105	°C
Cathode current, I_K	1	100	mA
Cathode voltage, V_{KA}	0	16	V

ELECTRICAL CHARACTERISTICS

Unless otherwise specified, these specifications apply over the operating ambient temperatures with $T_A = 25^\circ\text{C}$.

Parameter	Symbol	Test Conditions	CM431A			Units
			Min	Typ	Max	
Reference Input Voltage	V_{REF}	$I_K = 10\text{mA}, V_{KA} = V_{REF}, 0.5\%$	2.488	2.5	2.512	V
		$I_K = 10\text{mA}, V_{KA} = V_{REF}, 1.0\%$	2.475	2.5	2.525	V
		$I_K = 10\text{mA}, V_{KA} = V_{REF}, 1.5\%$	2.463	2.5	2.537	V
Reference Drift		$I_K = 10\text{mA}, V_{KA} = V_{REF}, 0^\circ\text{C} \leq T_A \leq 70^\circ\text{C}$		4	17	mV
Voltage Ratio, Ref to Cathode (note 4)		$I_K = 10\text{mA}, V_{KA} = 2.5\text{V to } 18\text{V}$		-1.4	-2.7	mV/V
Reference Input Current	I_{REF}	$I_K = 10\text{mA}, V_{KA} = V_{REF}$		2	4	μA
		$I_K = 10\text{mA}, V_{KA} = V_{REF}, 0^\circ\text{C} \leq T_A \leq 70^\circ\text{C}$			2.3	
Minimum Operating Current	I_{MIN}	$V_{KA} = V_{REF}$		0.4	1	mA
Off-State Cathode Current	I_{OFF}	$V_{KA} = 18\text{V}, V_{REF} = 0\text{V}$		0.1	1	μA
Dynamic Impedance	$ Z_{KA} $	$V_{KA} = V_{REF}, I_K = 1\text{mA to } 100\text{mA},$ $f \leq 1\text{kHz}$		0.2	0.5	Ω

Note 3: These parameters are guaranteed by design

Note 4: $\frac{\Delta V_{REF}}{\Delta V_{KA}}$ Ratio of change in reference input voltage to the change in cathode voltage

PARAMETER MEASUREMENT INFORMATION

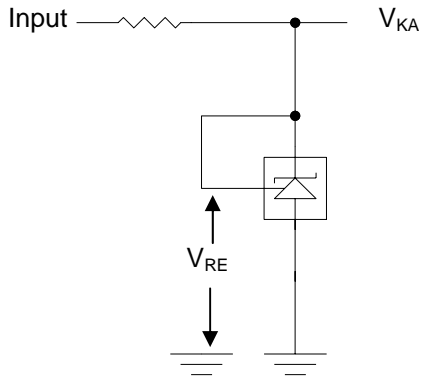
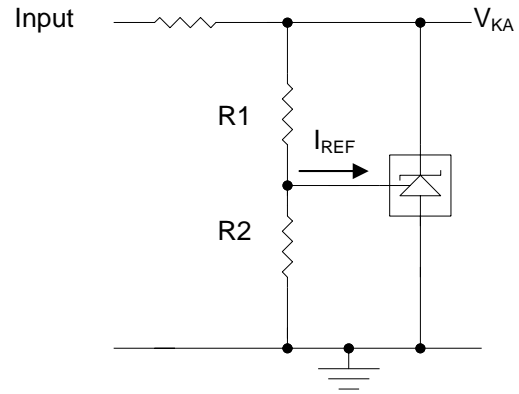

Figure 1. Test Circuit for $V_{KA} = V_{REF}$



$$V_{KA} = V_{REF} \left(1 + \frac{R1}{R2} \right) + I_{REF} \times R1$$

Figure 2. Test Circuit for $V_{KA} > V_{REF}$

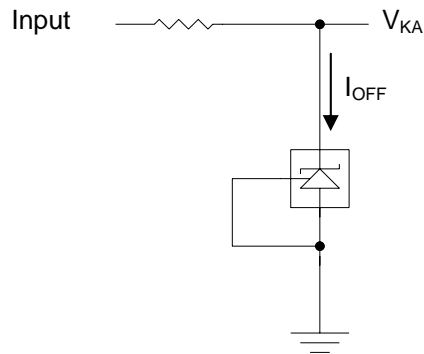
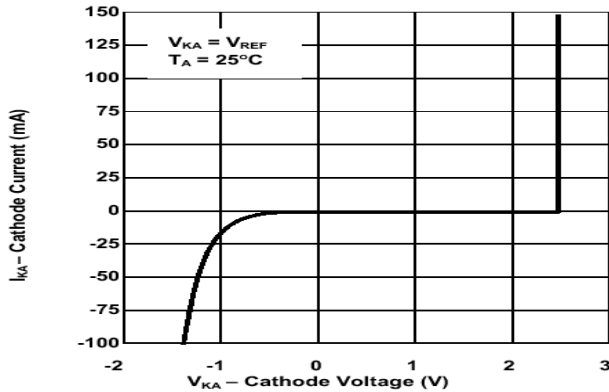

Figure 3. Test Circuit for I_{OFF}

TYPICAL CHARACTERISTICS

Cathode Current vs. Cathode Voltage



Cathode Current vs. Cathode Voltage

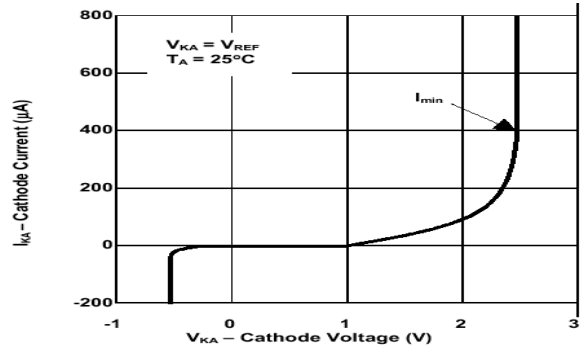

Ref. Input Voltage vs. Free-Air Temperature

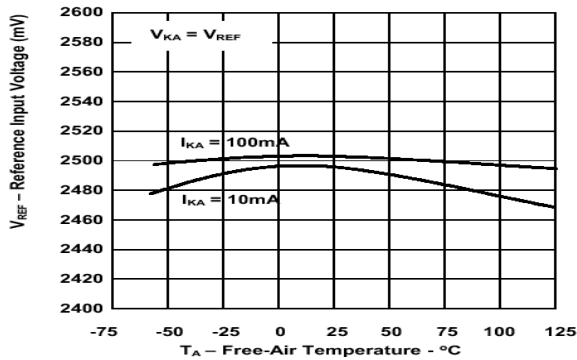

Ref. Input Current vs. Free-Air Temperature

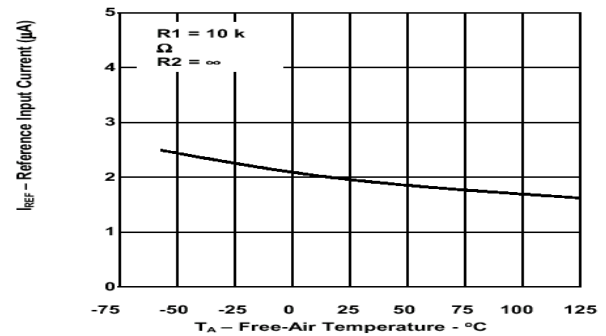

Stability Boundray Conditions

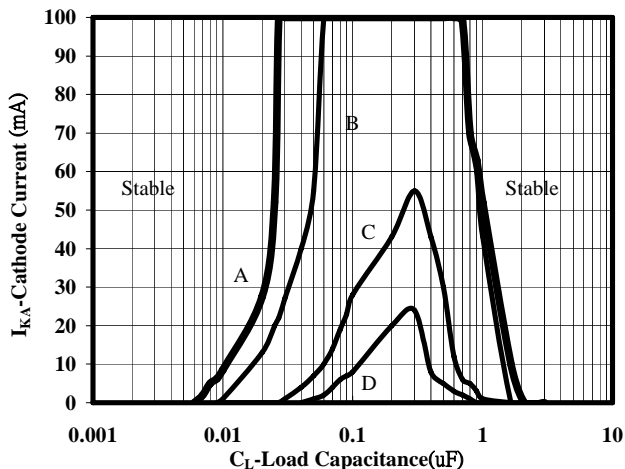

APPLICATION INFORMATION

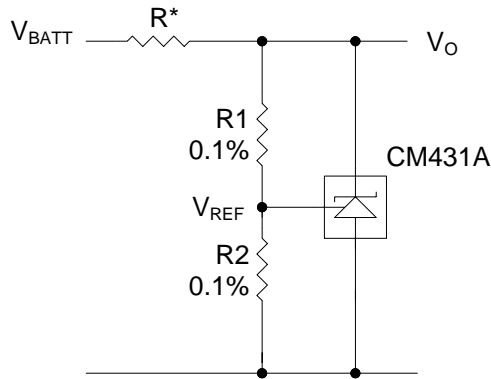

$$V_O = (1 + R1/R2) \times V_{REF}$$

Note: R should provide 1mA cathode current to the CM431A of minimum V_{BATT}

Figure 4. Shunt Regulator

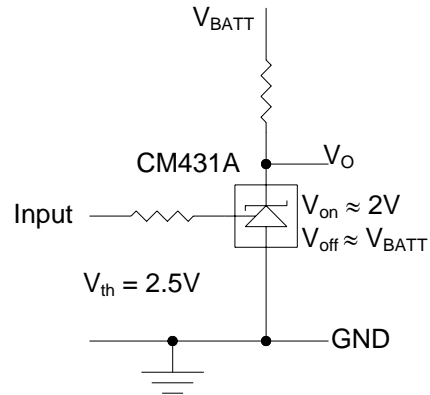
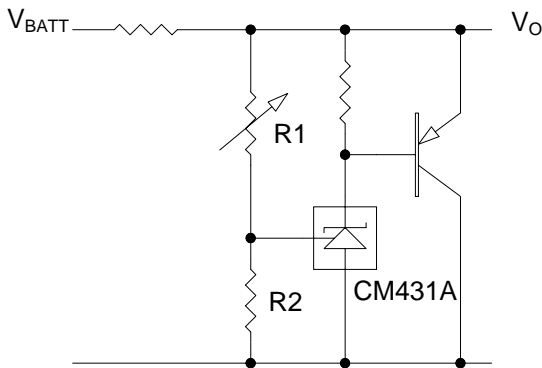

Figure 5. Single –Supply Comparator With Temperature compensated threshold.



$$V_O = (1 + R1/R2) \times V_{REF}$$

Figure 6. High-Current Shunt Regulator

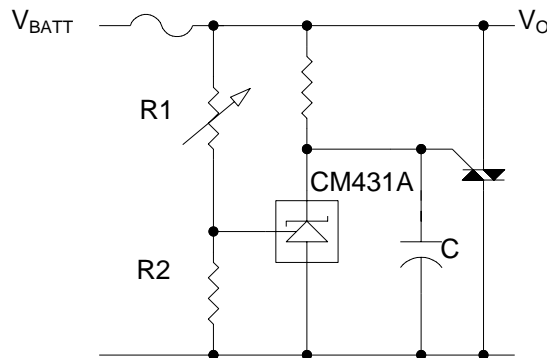

Figure 7. Crowbar Circuit

APPLICATION INFORMATION (continued)

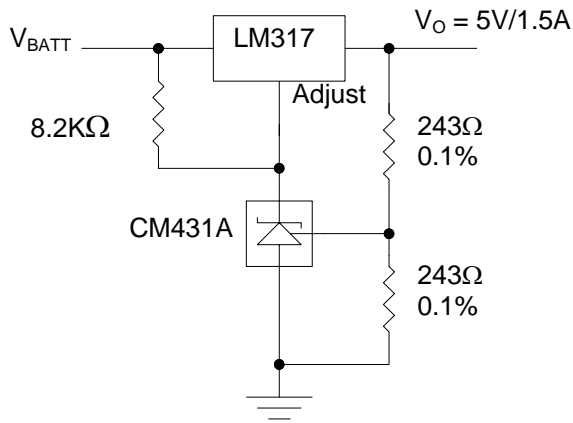

Figure 8. Precision 5V, 1.5A Regulator

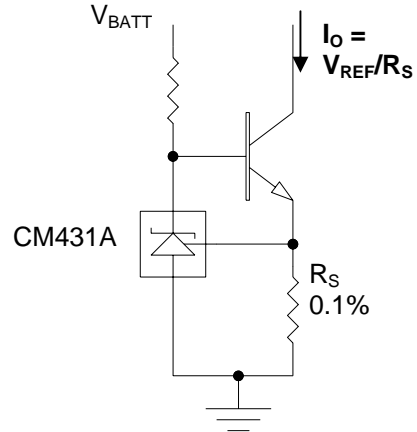
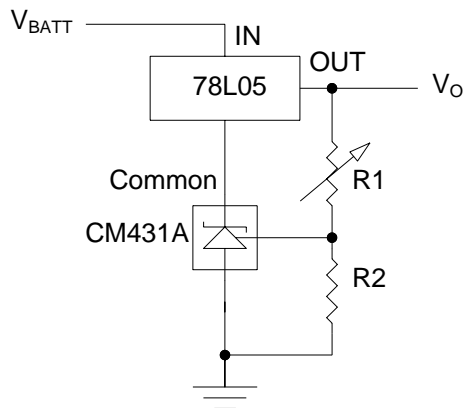

Figure 9. Precision Constant Current Sink



$$V_O = (1 + R1/R2) \times V_{REF}$$

$$\text{Min } V_O = V_{REF} + 5V$$

Figure 10. Output Control of a Three-Terminal Fixed Regulator

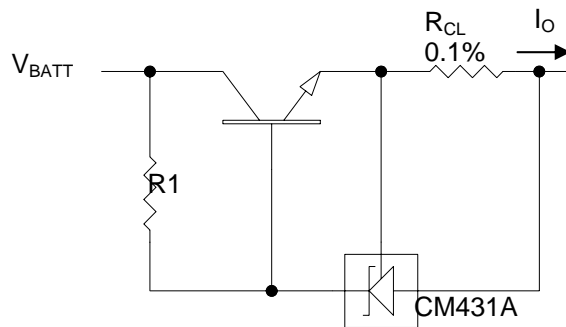

$$I_{OUT} = (V_{REF}/R_{CL}) + I_{KA}$$

$$R1 = V_{BATT}/((I_o/h_{FE}) + I_{KA})$$

Figure 11. Precision Current Limiter

PACKAGE DIMENSION

TO-92



SYMBOLS	DIMENSIONS IN MILLIMETERS			DIMENSIONS IN INCHES		
	MIN	NOM	MAX	MIN	NOM	MAX
A	3.45	3.56	3.66	0.136	0.140	0.144
A1	1.22	1.30	1.37	0.048	0.051	0.054
b	---	0.38	---	---	0.015	---
D	4.27	4.52	4.78	0.168	0.178	0.188
D1	4.14	4.29	4.45	0.163	0.169	0.175
E	4.32	4.57	4.83	0.170	0.180	0.190
L	12.98	13.49	14.00	0.511	0.531	0.551
e	---	1.27	---	---	0.050	---
theta	---	5°	---	---	5°	---
theta1	---	5°	---	---	5°	---

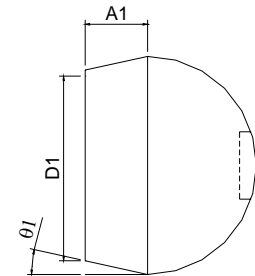
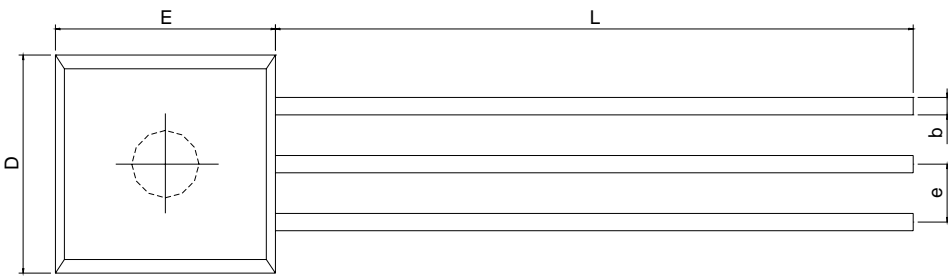

SOT-23-3

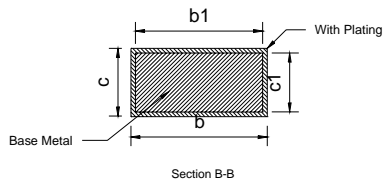
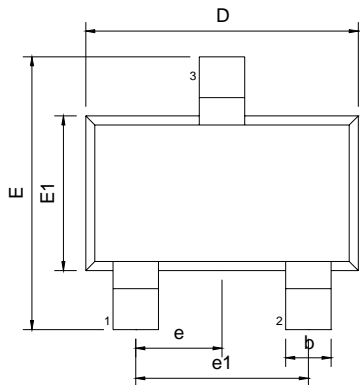

SYMBOLS	DIMENSIONS IN MILLIMETERS			DIMENSIONS IN INCHES		
	MIN	NOM	MAX	MIN	NOM	MAX
A	1.05	---	1.35	0.041	---	0.053
A1	0.05	---	0.15	0.002	---	0.006
A2	1.00	1.10	1.20	0.039	0.043	0.047
b	0.25	---	0.50	0.010	---	0.020
b1	0.25	0.40	0.45	0.010	0.016	0.018
c	0.08	---	0.20	0.003	---	0.008
c1	0.08	0.11	0.15	0.003	0.004	0.006
D	2.70	2.90	3.00	0.106	0.114	0.118
E	2.60	2.80	3.00	0.102	0.110	0.118
E1	1.50	1.60	1.70	0.059	0.063	0.067
L	0.35	0.45	0.55	0.014	0.018	0.022
L1	0.60 REF			0.024 REF		
e	0.95 BSC			0.037 BSC		
e1	1.90 BSC			0.075 BSC		
theta	0°	5°	10°	0°	5°	10°
theta1	3°	5°	7°	3°	5°	7°
theta2	6°	8°	10°	6°	8°	10°

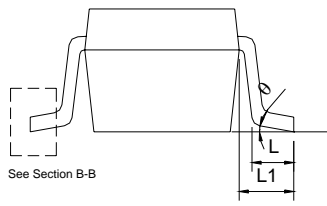
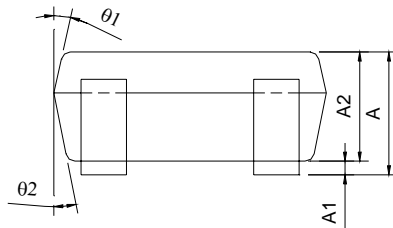

PACKAGE DIMENSION (CONTINUED)

SOT-23-5

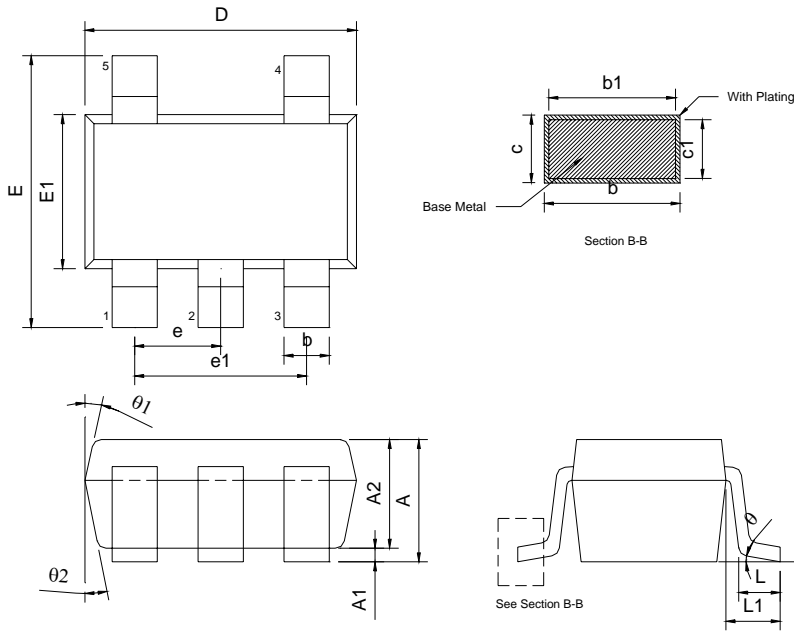

SYMBOLS	DIMENSIONS IN MILLIMETERS			DIMENSIONS IN INCHES		
	MIN	NOM	MAX	MIN	NOM	MAX
A	1.05	---	1.35	0.041	---	0.053
A1	0.05	---	0.15	0.002	---	0.006
A2	1.00	1.10	1.20	0.039	0.043	0.047
b	0.25	---	0.50	0.010	---	0.020
b1	0.25	0.40	0.45	0.010	0.016	0.018
c	0.08	---	0.20	0.003	---	0.008
c1	0.08	0.11	0.15	0.003	0.004	0.006
D	2.70	2.90	3.00	0.106	0.114	0.118
E	2.60	2.80	3.00	0.102	0.110	0.118
E1	1.50	1.60	1.70	0.059	0.063	0.067
L	0.35	0.45	0.55	0.014	0.018	0.022
L1	0.60 REF			0.024 REF		
e	0.95 BSC			0.037 BSC		
e1	1.90 BSC			0.075 BSC		
theta	0°	5°	10°	0°	5°	10°
theta1	3°	5°	7°	3°	5°	7°
theta2	6°	8°	10°	6°	8°	10°

SOT-89

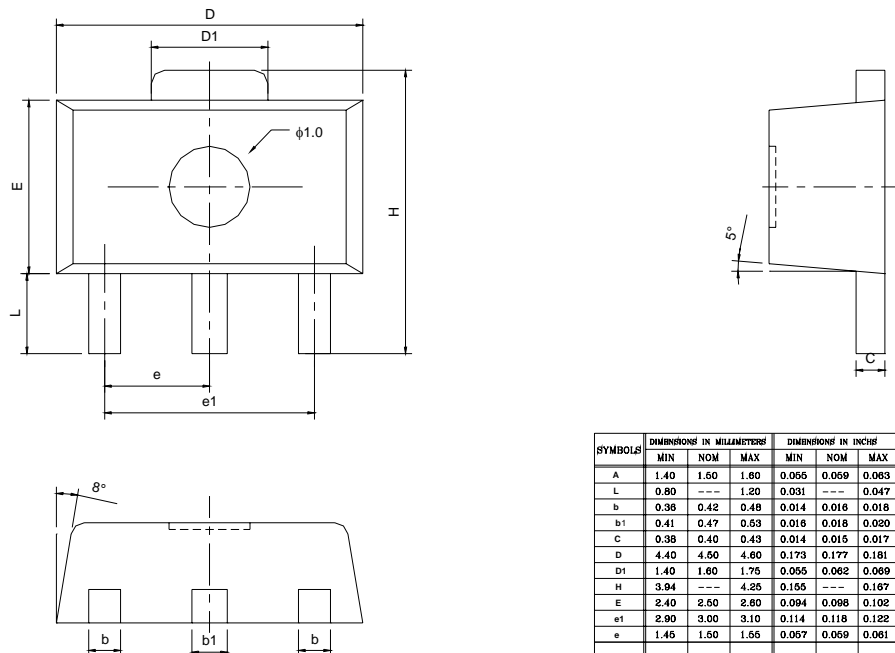

SYMBOLS	DIMENSIONS IN MILLIMETERS			DIMENSIONS IN INCHES		
	MIN	NOM	MAX	MIN	NOM	MAX
A	1.40	1.60	1.80	0.055	0.069	0.083
L	0.80	---	1.20	0.031	---	0.047
b	0.38	0.42	0.48	0.014	0.016	0.018
b1	0.41	0.47	0.53	0.016	0.018	0.020
c	0.38	0.40	0.43	0.014	0.015	0.017
D	4.40	4.60	4.80	0.173	0.177	0.181
D1	1.40	1.60	1.75	0.055	0.062	0.069
H	3.04	---	4.25	0.155	---	0.167
E	2.40	2.60	2.80	0.094	0.098	0.102
e1	2.90	3.00	3.10	0.114	0.118	0.122
e	1.45	1.60	1.65	0.057	0.069	0.061

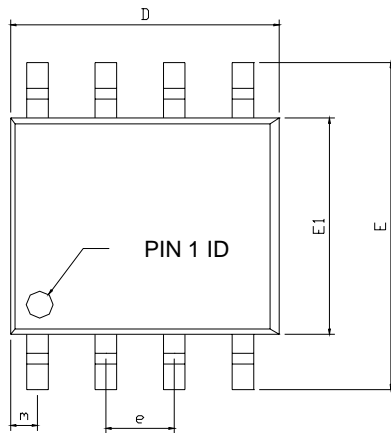
PACKAGE DIMENSION (CONTINUED)
8-PIN SOP (S08)

SYMBOLS	DIMENSIONS IN MILLIMETERS			DIMENSIONS IN INCHS		
	MIN	NOM	MAX	MIN	NOM	MAX
A1	0.10	---	0.25	0.004	---	0.010
A2	1.40	---	1.55	0.055	---	0.061
b	0.30	---	0.51	0.012	---	0.020
C	0.15	---	0.26	0.006	---	0.010
D	4.60	---	5.06	0.169	---	0.199
E	5.79	---	6.20	0.228	---	0.244
E1	3.76	---	4.01	0.148	---	0.158
e	---	1.27	---	---	0.050	---
L	0.38	---	0.69	0.015	---	0.035
m	0.43	---	0.69	0.017	---	0.027
θ	0°	---	8°	0°	---	8°

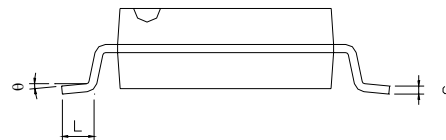
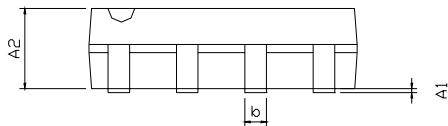



NUMBERING SCHEME

Ordering Number: CM431AXYZ (note1)
Ordering Number: CM431AGXYZ (note2)

note1:

- X : Suffix for Reference Voltage Tolerance (note 3)
- Y : Suffix for Temperature Range (note 4)
- Z : Suffix for Package Type (note 5)

note2:

- G : Suffix for Pb Free Product
- X : Suffix for Reference Voltage Tolerance (note 3)
- Y : Suffix for Temperature Range (note 4)
- Z : Suffix for Package Type (note 5)

note 3: see the Reference Voltage Tolerance Suffix Table

note 4:

Y= C: 0°C ~+105°C

note 5:

- Z is single alphabet with or without digits
- M233 : SOT-23-3 (TR only)
- M2R3: SOT-23-3 (TR only) but pin assignment is different with M233
- M235 : SOT-23-5 (TR only)
- M89:SOT-89(TR only)
- N:TO-92(TA only)
- S:SOP-8(TR only)

Reference Voltage Tolerance Suffix Table

Tolerance	Suffix
0.5%	A
1%	B
1.5%	E



IMPORTANT NOTICE

Champion Microelectronic Corporation (CMC) reserves the right to make changes to its products or to discontinue any integrated circuit product or service without notice, and advises its customers to obtain the latest version of relevant information to verify, before placing orders, that the information being relied on is current.

A few applications using integrated circuit products may involve potential risks of death, personal injury, or severe property or environmental damage. CMC integrated circuit products are not designed, intended, authorized, or warranted to be suitable for use in life-support applications, devices or systems or other critical applications. Use of CMC products in such applications is understood to be fully at the risk of the customer. In order to minimize risks associated with the customer's applications, the customer should provide adequate design and operating safeguards.

HsinChu Headquarter

5F, No. 11, Park Avenue II,
Science-Based Industrial Park,
HsinChu City, Taiwan
TEL: +886-3-5679979
FAX: +886-3-5679909

Sales & Marketing

7F-6, No.32, Sec. 1, Chenggong Rd.,
Nangang District, Taipei City 115,
Taiwan, R.O.C.
TEL : +886-2-2788 0558
FAX : +886-2-2788 2985
