

TOSHIBA BIPOLAR LINEAR INTEGRATED CIRCUIT SILICON MONOLITHIC

TA8690AN

PAL / NTSC DUAL MODE COLOR TV SINGLE CHIP SIGNAL PROCESSING IC

The TA8690AN is provided with the circuit of PIF, SIF, video, chroma, deflection. And the package the small DIP (shrink DIP with 54pins). With this item, the PAL / NTSC Dual Mode Color TV is to be composed of fewer components, and with small area.

FEATURES

PIF stage

- 3 Stage Variable Gain IF AMP
- High Speed response AGC (peak AGC) with dual time constants
- Single end AFT output with defeat function
- RF delay AGC output (Reverse AGC)
- internal black/white noise inverter

SIF stage

- Quadrature FM Detection Circuit
- Adjustment free Detection Circuit with ceramic discriminator
- High performance electronic attenuater circuit
- NF Preamplifier Circuit

Video stage

- Secondary Differential Picture Sharpness Circuit
- Contrast Control with Uni-color function
- Brightness Control with Pedestal Clamp Circuit
- Internal Blanking Circuit

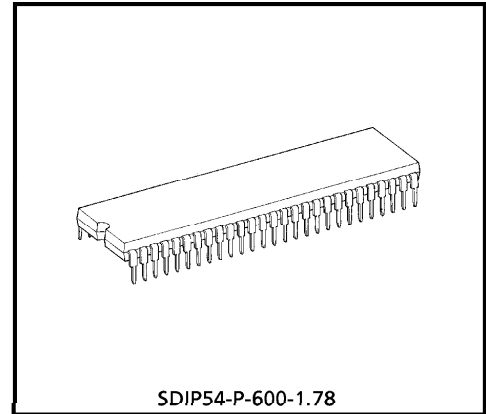

SDIP54-P-600-1.78

Weight : 5.44g (Typ.)

961001EBA2

- TOSHIBA is continually working to improve the quality and the reliability of its products. Nevertheless, semiconductor devices in general can malfunction or fail due to their inherent electrical sensitivity and vulnerability to physical stress. It is the responsibility of the buyer, when utilizing TOSHIBA products, to observe standards of safety, and to avoid situations in which a malfunction or failure of a TOSHIBA product could cause loss of human life, bodily injury or damage to property. In developing your designs, please ensure that TOSHIBA products are used within specified operating ranges as set forth in the most recent products specifications. Also, please keep in mind the precautions and conditions set forth in the TOSHIBA Semiconductor Reliability Handbook.
- The products described in this document are subject to foreign exchange and foreign trade control laws.
- The information contained herein is presented only as a guide for the applications of our products. No responsibility is assumed by TOSHIBA CORPORATION for any infringements of intellectual property or other rights of the third parties which may result from its use. No license is granted by implication or otherwise under any intellectual property or other rights of TOSHIBA CORPORATION or others.
- The information contained herein is subject to change without notice.

Chroma stage

- ACC Circuit
- Color Control Circuit
- Uni-Color Control Circuit
- Color Differential output
- Adjustment free APC Circuit
- Killer Circuit
- OSD interface with Brightness control
- PAL / NTSC system SW
- TINT Control Circuit at NTSC Mode

Deflection stage

- High performance sync. separation circuit
- Adjustment free Countdown system
- AFC Circuit
- Flyback pulse input with sync. output
- Horizontal Pre-Drive Output
- X-ray Protection Circuit
- Vertical Pulse Output
- 50Hz / 60Hz auto detector
- 50Hz / 60Hz manual SW

BLOCK DIAGRAM

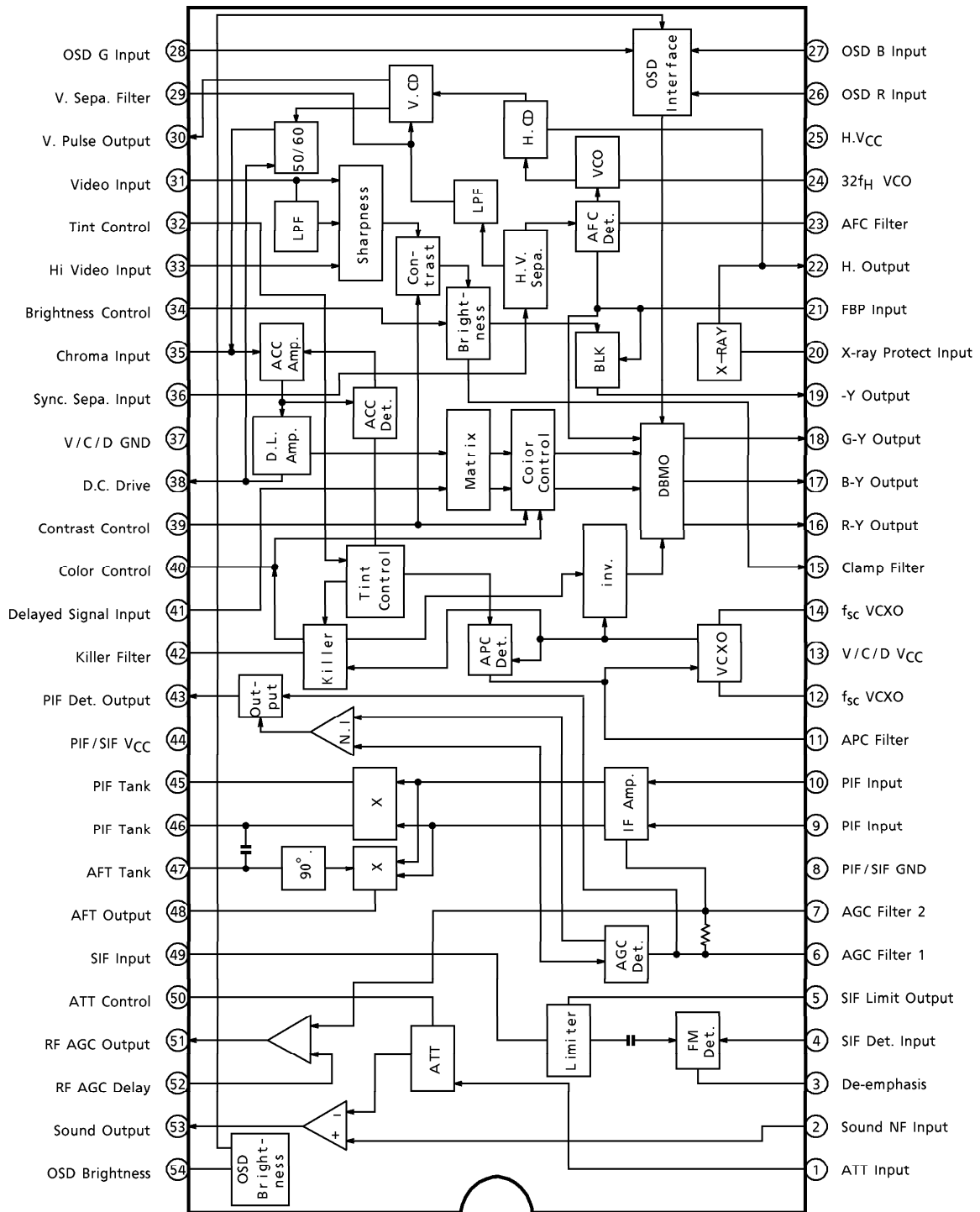

TERMINAL FUNCTION

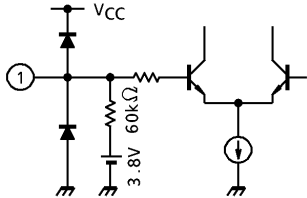
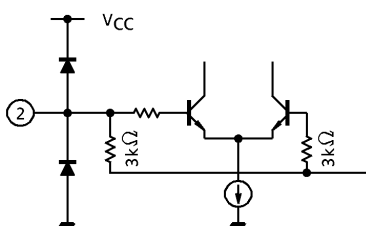
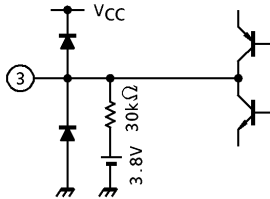
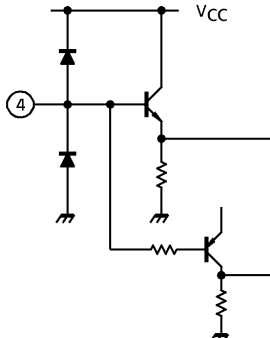
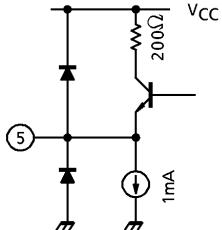
PIN No.	PIN NAME	FUNCTION	INTERFACE CIRCUIT
1	ATT Input	Input terminal for audio amplifier.	
2	Sound NF Input	NFB terminal for audio amplifier.	
3	De-emphasis	A SIF detection de-emphasis capacitor is connected.	
4	SIF Det. Input	A 4.5MHz tuned tank circuit is connected. The detector muting function is on when this terminal is connected to GND.	
5	SIF Limit Output	A sound carrier output to drive SIF tuned tank coil circuit.	

PIN No.	PIN NAME	FUNCTION	INTERFACE CIRCUIT
6 7	AGC Filter 1 AGC Filter 2	Pins 6 and 7 are AGC time constant terminals. A dual time constant system is adopted in order to achieve a high speed response.	
8	PIF/SIF GND	GND terminal for pin 39 V _{CC} .	—
9 10	PIF Input	PIF signal input terminal. Input impedance : 2.5kΩ Typ.	
11	APC Filter	APC filter time constant is connected. When killer works, automatic search circuit operates in order to widen the pull-in range. The search speed is also determined by the external filter time constant.	
12 14	f _{sc} VCXO	A f _{sc} X'tal is connected between pins 11 and 13. Pin 12 is a drive output and pin 14 is an input.	

PIN No.	PIN NAME	FUNCTION	INTERFACE CIRCUIT
13	V/C/D VCC	VCC terminal for Video, Chroma, Deflection.	—
15	Clamp Filter	A terminal for a pedestal clamp capacitor.	
16 17 18	R-Y Output B-Y Output G-Y Output	Color differential signal outputs.	
19	-Y Output	The output terminal of video signal which is processed by vertical blanking and horizontal blanking.	
20	X-ray Protect Input	The input terminal of the X-ray protector. Pin 21 horizontal drive terminal turns to low when the input voltage of this terminal exceeds the specified threshold voltage, 1.3V Typ.	
21	FBP Input	Input terminal for fly back pulse to horizontal AFC circuit (the integrator circuit for a sawtooth wave is provided internally). Pin 21 terminal voltage is clamped to 4.2V during Sync. pulse period.	

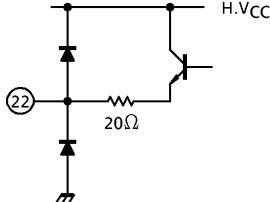
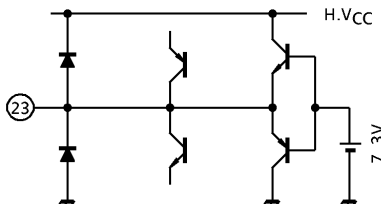
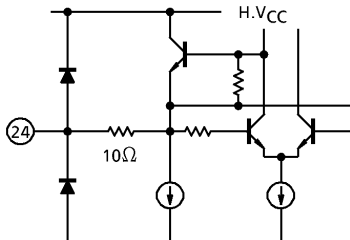
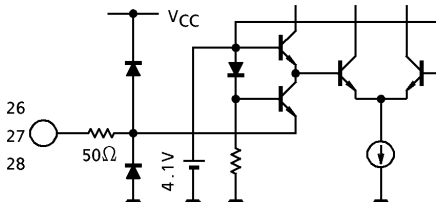
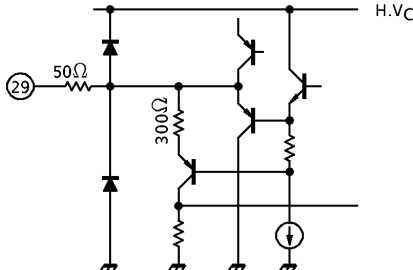
PIN No.	PIN NAME	FUNCTION	INTERFACE CIRCUIT
22	H. Output	Horizontal output terminal (emitter follower). Amplitude : 5.0V _{p-p} (Typ.) Duty : 43% (Typ.)	
23	AFC Filter	AFC filter is connected.	
24	32f _H VCO	Adjustment free 32f _H oscillator. A ceramic resonator is connected.	
25	H.VCC	VCC for Horizontal Deflection. H.VCC = 9V (Typ.) made by external parts.	—
26 27 28	OSD R Input OSD B Input OSD G Input	OSD (On Screen Display) signal input terminal. OSD switch circuit is enabled by sink current at the input terminal (0.3mA Typ.)	
29	V. Sepa. Filter	Vertical sync. separation filter is connected.	

PIN No.	PIN NAME	FUNCTION	INTERFACE CIRCUIT						
30	V. Pulse Output	Vertical pulse output terminal. (10H width positive pulse)							
31	Video Input	Input terminal of delayed video signal, 1V _{p-p} (Typ.).							
32	Tint Control	<p>The terminal for tint control. And also PAL/NTSC SW.</p> <table border="1" data-bbox="550 1137 869 1276"> <thead> <tr> <th>PIN VOLTAGE</th> <th>MODE</th> </tr> </thead> <tbody> <tr> <td>0.7V +</td> <td>NTSC</td> </tr> <tr> <td>0.7V -</td> <td>PAL</td> </tr> </tbody> </table>	PIN VOLTAGE	MODE	0.7V +	NTSC	0.7V -	PAL	
PIN VOLTAGE	MODE								
0.7V +	NTSC								
0.7V -	PAL								
33	Hi Video Input	The second order differential video signal input terminal and the picture sharpness control terminal.							

PIN No.	PIN NAME	FUNCTION	INTERFACE CIRCUIT
34	Brightness Control	Brightness control terminal.	
35	Chroma Input	Chroma signal input terminal. Recommendable input burst signal level is 100mV _{p-p} . 50Hz / 60Hz Detect out 60Hz : 1.2V 50Hz : 5.0V	
36	Sync. Sepa. Input	Video signal input for H/V sync. separator. Automatic slicer (slice level is approximately 50% of sync. signal) is adopted.	
37	V/C/D GND	GND for Video / Chroma / Deflection.	—
38	D.C. Drive	The chroma signal output for a 1H delay line driving.	

PIN No.	PIN NAME	FUNCTION	INTERFACE CIRCUIT
39	Contrast Control	<p>Video gain and color gain are controlled by this terminal simultaneously. When the terminal pin 39 Voltage is set to 1.4V~GND, V-out is stop and Contrast Control is min.</p>	
40	Color Control	<p>Color saturation control terminal. When the color killer circuit operates, this terminal voltage turns low.</p>	
41	Delayed Signal Input	<p>1H delayed chroma signal input. The signal phase shift between pins 38 and 41 should be less than 5 deg. The signal loss of the 1H delay line should be 16dB. 50Hz Mode : 3.0V 60Hz Mode : 6.0V</p>	

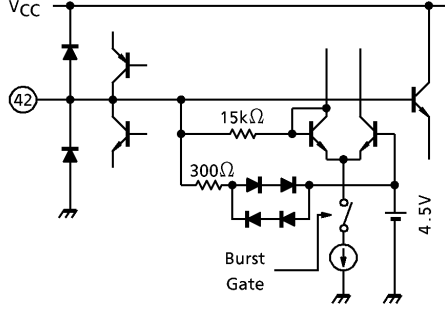
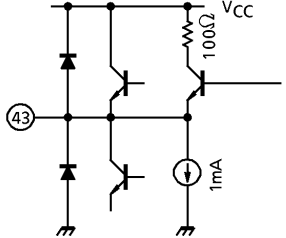
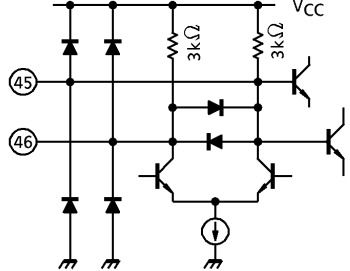
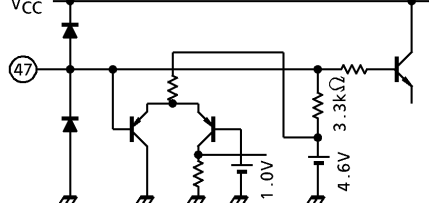
PIN No.	PIN NAME	FUNCTION	INTERFACE CIRCUIT																								
42	Killer Filter	<p>A capacitor for an ident filter is connected. For B/W signal, the terminal voltage of pin 42 is around 8V. When color signal is applied, an ident is correct the terminal voltage goes high whereas it goes low during incorrect ident.</p> <table border="1" data-bbox="582 660 813 907"> <tr> <td>Pin Voltage</td> <td>5.9V</td> <td>Killer Off</td> </tr> <tr> <td>Pin Voltage</td> <td>3.1V</td> <td>Killer On</td> </tr> <tr> <td></td> <td></td> <td>Killer Off</td> </tr> <tr> <td></td> <td></td> <td>PAL Mode</td> </tr> <tr> <td>Pin Voltage</td> <td>5.9V</td> <td>Killer Off</td> </tr> <tr> <td>Pin Voltage</td> <td>3.1V</td> <td>Killer On</td> </tr> <tr> <td></td> <td></td> <td>Killer Off</td> </tr> <tr> <td></td> <td></td> <td>NTSC Mode</td> </tr> </table>	Pin Voltage	5.9V	Killer Off	Pin Voltage	3.1V	Killer On			Killer Off			PAL Mode	Pin Voltage	5.9V	Killer Off	Pin Voltage	3.1V	Killer On			Killer Off			NTSC Mode	
Pin Voltage	5.9V	Killer Off																									
Pin Voltage	3.1V	Killer On																									
		Killer Off																									
		PAL Mode																									
Pin Voltage	5.9V	Killer Off																									
Pin Voltage	3.1V	Killer On																									
		Killer Off																									
		NTSC Mode																									
43	PIF Det. Output	An output terminal for detected video signal.																									
44	IF VCC	VCC for PIF/SIF.	—																								
45 46	PIF Tank	Terminals for a video Det. tank circuit.																									
47	AFT Tank	A single ended turned tank is connected. To defeat AFT, this terminal is GNDed by a 10kohm resistor.																									

PIN No.	PIN NAME	FUNCTION	INTERFACE CIRCUIT
48	AFT Output	AFT output terminal. AFT center voltage is determined by V_O .	
49	SIF Input	SIF signal input terminal.	
50	ATT Control	Volume control terminal. Controlled by 0 to 5V DC, suitable for μ -computer control interface. A linear taper potentiometer can be used. The Typ. attenuation range is 80dB.	
51	RF AGC Output	An open collector output for RF AGC. The gain is determined by an external load resistor.	
52	RF AGC Delay	The delay point of RF AGC is set by an applied external voltage.	
53	Sound Output	Emitter follower output for an audio output stage.	

PIN No.	PIN NAME	FUNCTION	INTERFACE CIRCUIT
54	OSD Brightness	OSD signal brightness control terminal.	

MAXIMUM RATINGS (Ta = 25°C)

CHARACTERISTIC	SYMBOL	RATING	UNIT
Power Supply Voltage	V _{CC}	15	V
Power Dissipation	P _{Dmax}	1923 (Note)	mW
Input Signal Voltage	e _{in}	5	V _{p-p}
Operating Temperature	T _{opr}	- 20~65	°C
Storage Temperature	T _{stg}	- 55~150	°C

(Note) When using the device at above Ta = 25°C, decrease the power dissipation by 15.4mW for each increase of 1°C.

P_D vs Ta CURVE

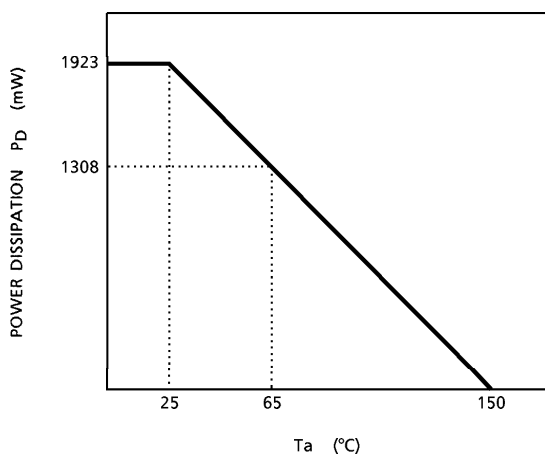

RECOMMENDED OPERATING CONDITION

PIN No.	PIN NAME	SYMBOL	MIN.	TYP.	MAX.	UNIT
13	V/C/D V _{CC}	V ₁₃	8.5	9.0	9.5	V
25	H.V _{CC}	V ₂₅	8.5	9.0	9.5	V
44	PIF/SIF V _{CC}	V ₄₄	8.5	9.0	9.5	V

ELECTRICAL CHARACTERISTICS

DC CHARACTERISTICS

DC voltage characteristics (Unless otherwise specified, $V_{CC} = 9V$, $H.V_{CC} = 9V$, $T_a = 25^\circ C$)

PIN No.	PIN NAME	SYMBOL	TEST CIRCUIT	MIN.	TYP.	MAX.	UNIT
1	ATT Input	V_1	—	3.3	3.8	4.5	V
2	Sound NF Input	V_2	—	3.2	3.9	4.5	V
3	De-emphasis	V_3	—	3.3	3.8	4.5	V
4	SIF Det. Input	V_4	—	2.4	2.8	3.3	V
5	SIF Limit Output	V_5	—	3.0	3.6	4.2	V
6	AGC Filter 1	V_6	—	7.8	8.5	9.0	V
7	AGC Filter 2	V_7	—	7.9	8.5	8.9	V
9	PIF Input	V_9	—	3.3	3.9	4.3	V
10	PIF Input	V_{10}	—	3.3	3.9	4.3	V
11	APC Filter	V_{11}	—	2.8	4.5	4.9	V
12	f_{sc} VCXO	V_{12}	—	4.3	5.2	6.1	V
14	f_{sc} VCXO	V_{14}	—	5.3	6.4	7.2	V
15	Clamp Filter	V_{15}	$V_{34} = 4.5V$	2.4	3.2	4.1	V
16	R-Y Output	V_{16}	—	4.8	5.5	6.0	V
17	B-Y Output	V_{17}	—	4.8	5.5	6.0	V
18	G-Y Output	V_{18}	—	4.8	5.5	6.0	V
19	-Y Output	V_{19}	—	—	—	—	V
20	X-ray Protect Input	V_{20}	—	—	—	—	V
21	FBP Input	V_{21}	—	—	—	—	V
22	H. Output	V_{22}	—	—	—	—	V
23	AFC Filter	V_{23}	—	6.7	7.3	8.7	V
24	$32f_H$ VCO	V_{24}	—	3.1	5.2	6.3	V
26	OSD R Input	V_{26}	—	1.3	1.9	2.3	V
27	OSD B Input	V_{27}	—	1.3	1.9	2.3	V
28	OSD G Input	V_{28}	—	1.3	1.9	2.3	V
29	V. Sepa. Filter	V_{29}	$H.V_{CC} : \text{Open}$	3.8	4.5	5.9	V
30	V. Pulse Output	V_{30}	—	4.5	5.0	5.5	V
31	Video Input	V_{31}	—	1.8	2.8	4.0	V
32	Tint Control	V_{32}	—	4.0	4.5	4.9	V
33	Hi Video Input	V_{33}	—	4.3	5.5	7.5	V
34	Brightness Control	V_{34}	$I_{in} = 20\mu A$	2.6	3.8	5.1	V
35	Chroma Input	V_{35}	—	4.1	5.0	5.7	V
36	Sync. Sepa. Input	V_{36}	—	1.8	2.1	3.7	V
38	D.C. Drive	V_{38}	—	6.5	7.2	8.2	V
39	Contrast Control	V_{39}	—	4.3	5.2	5.6	V
40	Color Control	V_{40}	—	3.9	4.5	4.9	V
41	Delayed Signal Input	V_{41}	—	3.5	4.5	4.9	V
42	Killer Filter	V_{42}	—	3.3	3.8	4.1	V
43	PIF Det. Output	V_{43}	—	4.0	4.5	5.0	V

PIN No.	PIN NAME	SYMBOL	TEST CIRCUIT	MIN.	TYP.	MAX.	UNIT
45	PIF Tank	V ₄₅	—	6.0	6.6	7.2	V
46	PIF Tank	V ₄₆	—	6.0	6.6	7.2	V
47	AFT Tank	V ₄₇	—	2.4	3.0	3.6	V
48	AFT Output	V ₄₈	—	2.0	4.5	6.0	V
49	SIF Input	V ₄₉	—	2.4	3.0	3.7	V
50	ATT Control	V ₅₀	—	—	—	—	V
51	RF AGC Output	V ₅₁	—	—	—	—	V
52	RF AGC Delay	V ₅₂	—	5.6	6.2	6.6	V
53	Sound Output	V ₅₃	—	3.2	4.1	4.6	V
54	OSD Brightness	V ₅₄	—	—	—	—	V

DC current characteristics (Unless otherwise specified, $V_{CC} = 9V$, $H.V_{CC} = 9V$, $T_a = 25^\circ C$)

PIN No.	PIN NAME	SYMBOL	TEST CIRCUIT	MIN.	TYP.	MAX.	UNIT
13	V/C/D V_{CC}	I ₁₃	—	25	50	75	mA
25	H. V_{CC}	I ₂₅	—	7	13.5	21	mA
44	PIF/SIF V_{CC}	I ₄₄	—	25	43.5	60	mA

AC CHARACTERISTICS (Unless otherwise specified, $V_{CC} = 9V$, $H.V_{CC} = 9V$, $T_a = 25^\circ C$)
PIF stage

CHARACTERISTIC	SYMBOL	TEST CIR-CUIT	TEST CONDITION	MIN.	TYP.	MAX.	UNIT
Input Sensitivity	$V_{IN\ MIN}$	1	(Note 1)	34	40	46	$dB_{\mu V}$
Maximum IF Input Level	$V_{IN\ MAX}$	1	(Note 2)	100	111	—	$dB_{\mu V}$
IF AGC Range	ΔA	1	(Note 3)	60	71	—	dB
Differential Gain	D_G	1	(Note 4)	—	—	10	%
Differential Phase	D_p	1	(Note 4)	—	—	7	°
No-Signal Level	V_0	1	(Note 5)	4.1	4.5	4.8	V
Sync. Tip Level	V_{SYNC}	1	(Note 6)	2.2	2.4	2.7	V
Video Output Level	V_{OUT}	1	(Note 6)	1.4	1.8	2.1	V_{p-p}
Video Frequency Characteristic	f_V	1	(Note 7)	6.0	8.3	—	MHz
White Noise Inverter Level	V_{WTH}	1	(Note 8)	5.1	5.4	5.7	V
White Noise Clamp Level	V_{WCL}	1	(Note 8)	3.6	3.9	4.2	V
Black Noise Inverter Level	V_{BTH}	1	(Note 8)	1.2	1.8	2.1	V
Black Noise Clamp Level	V_{BCL}	1	(Note 8)	3.2	3.5	4.0	V
Carrier Suppression Ratio	C_L	1	(Note 9)	40	58	—	dB
Harmonic Suppression Ratio	I_{2nd}	1	(Note 9)	40	44	—	dB
AFT Sensitivity	$\Delta f / \Delta V$	1	(Note 10)	15	23	30	kHz/V
AFT Characteristics	A	1	(Note 10)	6.0	8.7	—	V
	B / A	1	(Note 10)	20	35	55	%
	C / A	1	(Note 10)	25	28	30	%
AFT Center Voltage	$V_{43(0)}$	1	(Note 11)	3.5	4.5	5.5	V
No Signal Offset	ΔV_{43}	1	(Note 11)	-1.5	0	1.5	V
Intermodulation	I_{920}	1	(Note 12)	32	47	—	dB
Input Impedance	Z_{IN}	1	(Note 13)	1.75	2.5	3.25	$k\Omega$

SIF stage

CHARACTERISTIC	SYMBOL	TEST CIR-CUIT	TEST CONDITION	MIN.	TYP.	MAX.	UNIT
FM Detection Output Level	V_{OD}	1	(Note 14)	150	230	350	mV_{rms}
Input Limiting Sensitivity	V_{IN}	1	(Note 15)	—	34	45	$dB_{\mu V}$
AM Rejection Ratio	AMR	1	(Note 16)	30	53	—	dB
Band Width (3dB)	$\pm \Delta f_G$	1	(Note 17)	150	300	—	kHz
THD Band Width (1.5%)	$\pm \Delta f_D$	1	(Note 18)	150	230	—	kHz
ATT AC Gain	G_{ATT}	1	(Note 19)	3.0	5.0	8.0	dB
ATT Max. Attenuation Volume	G_{ATTMAX}	1	(Note 20)	65	80	—	dB
AF Amp AC Gain	$G_V\ AF$	1	(Note 21)	16	20	23	dB

Video stage

CHARACTERISTIC	SYMBOL	TEST CIR-CUIT	TEST CONDITION	MIN.	TYP.	MAX.	UNIT
Y Input Impedance	INP	2	(Note 22)	11	15	20	$k\Omega$
SHR Input Impedance	SHR INP	2	(Note 23)	11	15	20	$k\Omega$
Y Input Dynamic Range	D_{ynY}	2	(Note 24)	2.0	3.0	—	V_{p-p}
SHR Input Dynamic Range	D_{ynSHR}	2	(Note 25)	0.3	0.5	—	V_{p-p}
Max. Video Output Level	Y_{max}	2	(Note 26)	8.0	8.4	9.0	V
Min. Video Output Level	Y_{min}	2	(Note 26)	—	0.3	0.7	V
Video Output Drive Current	Y_{Isink}	2	(Note 27)	1.3	2.0	3.0	mA
Video AC Gain	G_Y	2	(Note 28)	9	12	15	dB
SHR AC Gain	G_{SHR}	2	(Note 29)	25	30	35	dB
Video Frequency Characteristic	f_Y	2	(Note 30)	6.8	8.0	—	MHz
Brightness Control Sensitivity	G_{BRT}	2	(Note 31)	2.0	3.0	4.0	
Brightness Control Voltage	V_{BRT}	2	(Note 32)	3.5	4.0	4.5	V
DC Restoration	T_{DC}	2	(Note 33)	95	99	—	%
Clamp Terminal Voltage	V_{CLAMP}	2	(Note 34)	2.5	3.3	3.8	V
Contrast Control Voltage	ΔV_{CONT}	2	(Note 35)	1.0	1.25	1.5	V
Contrast Gain Variable Range	ΔG_{CONT}	2	(Note 35)	11	17	19	dB
Frequency Response Dependence on Contrast Control	ΔG_{fCONT}	2	(Note 36)	—	0.7	1.2	dB
Picture Control Gain Range	ΔG_{SHR}	2	(Note 37)	20	25	—	dB
Picture Control Voltage Range	ΔV_{SHR}	2	(Note 38)	0.9	1.2	1.5	V
V-BLK Pulse Output Level	V_{VBLK}	2	(Note 39)	8.5	—	—	V
H-BLK Pulse Output Level	V_{HBLK}	2	(Note 39)	8.5	—	—	V
V-BLK Pulse Width (50Hz)	$VPVBLK50$	2	(Note 39)	—	21	—	H
V-BLK Pulse Width (60Hz)	$VPVBLK60$	2	(Note 39)	—	16	—	H
Delay of H-BLK Pulse Input	t_{DBS}	2	(Note 39)	—	—	0.5	μs

Chroma stage

CHARACTERISTIC	SYMBOL	TEST CIRCUIT	TEST CONDITION	MIN.	TYP.	MAX.	UNIT
ACC Characteristic	e_a	3	(Note 40)	0.5	0.85	—	V_{p-p}
	A	3	(Note 40)	0.9	1.0	1.2	Ratio
Unicolor Control Voltage Range	ΔY_{UNI}	3	(Note 41)	0.8	1.2	1.6	V
Unicolor Control Gain Range	ΔG_{UNI}	3	(Note 41)	20	—	—	dB
Unicolor Control Phase Change	$\Delta \theta_{UNI}$	3	(Note 42)	—	—	± 5	$^\circ$
Color Control Voltage Range	ΔV_{COL}	3	(Note 43)	0.8	1.2	1.6	V
Color Control Gain Range	ΔG_{COL}	3	(Note 43)	20	—	—	dB
Color Control Phase Change	$\Delta \theta_{COL}$	3	(Note 44)	—	—	± 5	$^\circ$
Color Control Residual	e_c	3	(Note 45)	—	—	30	mV_{p-p}
Tint Control Voltage Range	ΔV_{TIN}	3	(Note 46)	0.8	1.5	2.5	V
Tint Control Phase Range (3.58MHz)	$\Delta \theta_{3-1}$	3	(Note 46)	35	50	—	$^\circ$
	$\Delta \theta_{3-2}$	3	(Note 46)	35	50	—	$^\circ$
Tint Control Phase Range (4.43MHz)	$\Delta \theta_{4-1}$	3	(Note 46)	35	50	—	$^\circ$
	$\Delta \theta_{4-2}$	3	(Note 46)	35	50	—	$^\circ$
PAL/NTSC SW Voltage	$V_{P/N}$	3	(Note 47)	0.4	0.7	1.0	V
Killer Sensitivity (3.58MHz)	e_b	3	(Note 48)	—	1.0	3.0	mV_{p-p}
Killer Sensitivity (4.43MHz)	e_b	3	(Note 48)	—	1.0	3.0	mV_{p-p}
Killer Voltage	V_{KIL1}	3	(Note 49)	4.5	4.8	5.1	V
	V_{KIL2}	3	(Note 49)	3.8	4.1	4.4	V
Ident Sensitivity	e_i	3	(Note 50)	—	1.0	3.0	mV_{p-p}
Ident Voltage	V_{ID1}	3	(Note 51)	5.3	5.6	5.9	V
	V_{ID2}	3	(Note 51)	2.7	3.0	3.3	V
APC Pull-In Range (3.58MHz)	H Δf_{3PH}	3	(Note 52)	400	500	—	Hz
	L Δf_{3PL}	3	(Note 52)	500	1000	—	Hz
APC Hold Range (3.58MHz)	H Δf_{3HH}	3	(Note 52)	—	500	—	Hz
	L Δf_{3HL}	3	(Note 52)	—	500	—	Hz
APC Pull-In Range (4.43MHz)	H Δf_{4PH}	3	(Note 52)	300	500	—	Hz
	L Δf_{4PL}	3	(Note 52)	500	1000	—	Hz
APC Hold Range (4.43MHz)	H Δf_{4HH}	3	(Note 52)	—	500	—	Hz
	L Δf_{4HL}	3	(Note 52)	—	500	—	Hz
Frequency Sensitivity (3.58MHz)	β_3	3	(Note 53)	—	1.5	—	Hz/V
Frequency Sensitivity (4.43MHz)	β_4	3	(Note 53)	—	0.9	—	Hz/V
Demodulation Color Differential Output	R e_R	3	(Note 54)	2.9	3.6	4.3	V_{p-p}
	G e_G	3	(Note 54)	1.7	2.1	2.5	V_{p-p}
	B e_B	3	(Note 54)	3.3	4.0	4.7	V_{p-p}
Max. Demodulation Color Differential Output	R e_{Rmax}	3	(Note 55)	4.8	5.5	6.2	V_{p-p}
	G e_{Gmax}	3	(Note 55)	3.0	3.4	3.8	V_{p-p}
	B e_{Bmax}	3	(Note 55)	4.8	5.5	6.2	V_{p-p}

CHARACTERISTIC	SYMBOL	TEST CIR-CUIT	TEST CONDITION	MIN.	TYP.	MAX.	UNIT
Demodulation Relative Amplitude (NTSC)	R/B	NV_R/V_B	3 (Note 56)	0.8	0.9	1.1	Ratio
	G/B	NV_G/V_B	3 (Note 56)	0.28	0.32	0.48	Ratio
Demodulation Relative Amplitude (PAL)	R/B	PV_R/V_B	3 (Note 56)	0.43	0.58	0.70	Ratio
	G/B	PV_G/V_B	3 (Note 56)	0.27	0.37	0.46	Ratio
Demodulation Relative Phase (NTSC)	R-B	$N\theta_{R-B}$	3 (Note 56)	100	110	120	°
	G-B	$N\theta_{G-B}$	3 (Note 56)	225	235	245	°
Demodulation Relative Phase (PAL)	R-B	$P\theta_{R-B}$	3 (Note 56)	78	95	96	°
	G-B	$P\theta_{G-B}$	3 (Note 56)	226	236	240	°
Demodulation Output Residual Carrier	R	V_{Rcw}	3 (Note 57)	—	—	20	mV _{p-p}
	G	V_{Gcw}	3 (Note 57)	—	—	10	mV _{p-p}
	B	V_{Bcw}	3 (Note 57)	—	—	20	mV _{p-p}
Demodulation Output Residual Harmonic	R	V_{RHC}	3 (Note 57)	—	—	100	mV _{p-p}
	G	V_{GHC}	3 (Note 57)	—	—	50	mV _{p-p}
	B	V_{BHC}	3 (Note 57)	—	—	100	mV _{p-p}
Demodulation Output Band Width	R	f_{DEMOR}	3 (Note 58)	0.8	1.0	2.0	MHz
	G	f_{DEMOG}	3 (Note 58)	0.8	1.0	2.0	MHz
	B	f_{DEMOB}	3 (Note 58)	0.8	1.0	2.0	MHz
Demo. Voltage Difference	ΔV_{COL}	3 (Note 59)		-0.3	0	+0.3	V
D.L. AMP. Characteristic	V_{DL}	3 (Note 60)		0.7	1.0	1.3	V _{p-p}
Sweeper Amplitude	S_{V1}	3 (Note 61)		4.5	5.0	5.5	V
	S_{V2}	3 (Note 61)		3.5	4.0	4.5	V
	S_V	3 (Note 61)		0.8	1.0	1.2	V _{p-p}
Sweeper Period	S_{t1}	3 (Note 61)		80	100	120	ms
	S_{t2}	3 (Note 61)		5	10	15	ms
	S_t	3 (Note 61)		80	110	140	ms

Deflection stage

CHARACTERISTIC	SYMBOL	TEST CIR-CUIT	TEST CONDITION	MIN.	TYP.	MAX.	UNIT
Sync. Sepa. Sense Current	I_{IN}	4 (Note 62)		10	20	30	μA
H.AFC Detection Current	I_{DET}	4 (Note 63)		200	300	400	μA
H.AFC Detection Stop Period (50Hz)	$50T_{CO1}$	4 (Note 64)		—	309	—	H
	$50T_{CO2}$	4 (Note 64)		—	5	—	H
H.AFC Detection Stop Period (60Hz)	$60T_{CO1}$	4 (Note 64)		—	259	—	H
	$60T_{CO2}$	4 (Note 64)		—	5	—	H
32f _H VCO Oscillation Starting Voltage	V_{fH}	4 (Note 65)		2.0	3.0	4.0	V
H.OUT Starting Voltage	V_H	4 (Note 65)		4.0	4.4	5.0	V
Horizontal Free-Run Frequency	f_o	4 (Note 66)		15.475	15.625	15.775	kHz

CHARACTERISTIC		SYMBOL	TEST CIR-CUIT	TEST CONDITION	MIN.	TYP.	MAX.	UNIT
Horizontal Pull-In Range		Δf_H PULL	4	(Note 67)	± 500	—	—	kHz
Horizontal Hold Range		Δf_H HOLD	4	(Note 67)	± 500	—	—	kHz
Hor. OSC. Control Sensitivity		β_H	4	(Note 68)	4.0	5.5	7.0	Hz / mV
Hor. Output Pulse Duty		T	4	(Note 69)	41	43	45	%
X-ray Protector Sense Voltage		V_{ON19}	4	(Note 70)	1.1	1.3	1.5	V
X-ray Protector Hold Voltage		V_{HOLD19}	4	(Note 70)	—	—	2.5	V
Horizontal Output Voltage		V_{HH}	4	(Note 71)	4.7	5.0	5.3	V
		V_{HL}	4	(Note 71)	—	0	0.1	V
Vertical Pulse Width		V_p	4	(Note 72)	—	10	—	H
Vertical Output Voltage		V_{VH}	4	(Note 72)	4.7	5.0	5.3	V
		V_{VL}	4	(Note 72)	—	0	0.1	V
Vertical Pull-In Range	(50Hz)	$50f_{PV1}$	4	(Note 73)	—	260.5	—	H
		$50f_{PV2}$	4	(Note 73)	—	353	—	H
	(60Hz)	$60f_{PV1}$	4	(Note 73)	—	232	—	H
		$60f_{PV2}$	4	(Note 73)	—	297	—	H
Ver. Free-Run Frequency	(50Hz)	$50V_{free}$	4	(Note 74)	—	353	—	H
	(60Hz)	$60V_{free}$	4	(Note 74)	—	297	—	H
50Hz / 60Hz Switching Voltage		V_{SET50}	4	(Note 75)	5.5	6.0	6.5	V
		V_{SET60}	4	(Note 75)	2.5	3.0	3.5	V
50Hz / 60Hz Detection Voltage		V_{DET50}	4	(Note 75)	4.5	5.0	5.5	V
		V_{DET60}	4	(Note 75)	0.5	1.0	1.5	V

OSD interface stage

CHARACTERISTIC		SYMBOL	TEST CIR-CUIT	TEST CONDITION	MIN.	TYP.	MAX.	UNIT
OSD Input ON Current		I_{ON}	5	(Note 76)	0.2	0.3	0.4	mA
OSD Input OFF Current		I_{OFF}	5	(Note 77)	0.15	0.22	0.3	mA
OSD Output HIGH Level		V^H_{OUT}	5	(Note 78)	6.5	6.7	6.9	V
OSD Output LOW Level		V^L_{OUT}	5	(Note 79)	4.4	4.7	5.0	V
Output Rise Time		τ_R	5	(Note 80)	—	15	100	ns
Rise Propagation Delay Time		t_{pR}	5	(Note 80)	—	40	100	ns
Output Fall Time		τ_F	5	(Note 80)	—	25	100	ns
Fall Propagation Delay Time		t_{pF}	5	(Note 80)	—	15	400	ns
Y→OSD Switching Time		$\tau_{Y\rightarrow 0}$	5	(Note 81)	—	15	100	ns
Y→OSD Switching Delay Time		$t_{Y\rightarrow 0}$	5	(Note 81)	—	40	100	ns
OSD→Y Switching Time		$\tau_{0\rightarrow Y}$	5	(Note 81)	—	10	100	ns
OSD→Y Switching Delay Time		$t_{0\rightarrow Y}$	5	(Note 81)	—	15	100	ns
OSD Brightness Control Voltage		V_{OSDBRT}	5	(Note 82)	3.4	4.5	5.5	V
OSD Brightness Sensitivity		G_{OSDBRT}	5	(Note 82)	0.5	1.0	1.5	

TEST CONDITIONS

PIF stage

NOTE	ITEM	TEST CONDITIONS (UNLESS OTHERWISE SPECIFIED $V_{CC} = 9V$, $T_a = 25 \pm 3^\circ C$)					TEST METHOD
		SW & VR MODES					
		SW1	SW2	SW3	SW4	SW5	
1	Input Sensitivity	b	OFF	OFF	ON	b	(1) From TP9, input the following signal : $f_0 = 38.9MHz$, 15.75kHz 30% AM, 84dB μV . (2) Measure the 15.75kHz output level at TP43A (V_{TP}). (3) Lower the TP9 input level, and measure this level when the signal output from TP43A drops to -3dB of the V_{TP} .
2	Maximum IF Input Level	b	OFF	OFF	ON	b	(1) From TP9, input the following signal : $f_0 = 38.9MHz$, 15.75kHz 30% AM, 84dB μV . (2) Measure the 15.75kHz output level at TP43A (V_{TP}). (3) Raise the TP9 input level, and measure this input level when the level of the signal output from TP43A reaches +3dB of the V_{TP} .
3	IF AGC Range	b	OFF	OFF	ON	b	(1) From TP9, input the following signal : $f_0 = 38.9MHz$, 15.75kHz 30% AM, 84dB μV . (2) Measure the 15.75kHz output level at TP43A (V_{TP}). (3) $\Delta A = V_{INmax} - V_{INmin}$
4	Differential Gain Differential Phase	b	OFF	OFF	ON	b	(1) From TP9, input the following signal : $f_0 = 38.9MHz$, linearity 87.5% AM, 84dB μV (2) Monitor the TP43 output signal with a vector scope, and measure DG and DP.
5	No-Signal Level	b	ON	OFF	ON	b	(1) Apply 5V to TP7. (2) Measure the DC voltage on TP43.
6	Sync. Tip Level Video Output Level	b	OFF	OFF	ON	b	(1) From TP9, input the following signal : $f_0 = 38.9MHz$, black and white mode 87.5% AM, 84dB μV . (2) Measure the sync. signal peak voltage and amplitude of the video signal output from TP43.

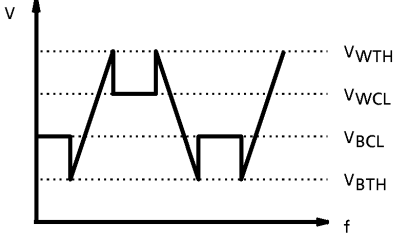
NOTE	ITEM	TEST CONDITIONS (UNLESS OTHERWISE SPECIFIED $V_{CC} = 9V$, $T_a = 25 \pm 3^\circ C$)					TEST METHOD
		SW & VR MODES					
		SW1	SW2	SW3	SW4	SW5	
7	Video Frequency Characteristic	b	OFF or ON	OFF	ON	b	(1) From TP9, input a $f_0 = 38.9MHz$, $84dB\mu V$ signal. (2) Measure the voltage on TP7 and fix to that voltage using the external power supply. (3) SW2 on (4) From TP9, input a composite signal of $f_{01} = 38.9MHz$, $84dB\mu V$ and $f_{02} = 37.9MHz$, $74dB\mu V$. (5) Measure the TP43 output level. (V_{OSG2}) (6) Lower the frequency of f_{02} , and determine the f_{02} frequency when the TP38 output level drops to $-3dB$ of V_{OSG2} ($f_{02}(-3)$). (7) $f_V = f_{01} - f_{02}(-3)$
8	White Noise Inverter Level White Noise Clamp Level Black Noise Inverter Level Black Noise Clamp Level	b	ON	OFF	ON	b	(1) From TP9, input an $84dB\mu V$ frequency sweep signal ($37MHz \sim 47MHz$). (2) Connect an oscilloscope to TP43 and vary the TP7 voltage. Fix when the following characteristics are obtained.  (3) Measure V_{WTH} , V_{WCL} , V_{BTH} , and V_{BCL} .
9	Carrier Suppression Ratio Harmonic Suppression Ratio	b	ON	OFF	ON	b	(1) From TP9, input the following signal : $f_0 = 38.9MHz$, $15.75kHz$ 87.5% AM. (2) Set the TP7 voltage so that the output of TP43 is $2V_{p-p}$. (3) Stop the modulation, and measure the carrier signal leak voltage at TP43 using a spectrum analyzer. $C_L = 20 \log (2 / \text{carrier signal leakage})$ (4) Similarly, measure the leakage of the 2nd and 3rd harmonics.

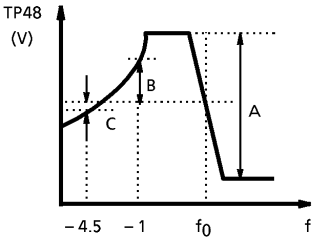
NOTE	ITEM	TEST CONDITIONS (UNLESS OTHERWISE SPECIFIED $V_{CC} = 9V$, $T_a = 25 \pm 3^\circ C$)					TEST METHOD
		SW & VR MODES					
		SW1	SW2	SW3	SW4	SW5	
10	AFT Sensitivity AFT Characteristics	b	OFF	OFF	ON	b	(1) From TP9, input a $f_0 = 38.9MHz$, $84dB\mu V$ signal. (2) Measure the change in voltage on TP48 when the frequency of the input signal changes by $\Delta 20kHz$ (ΔV_{48}). (3) Vary the input frequency to obtain the following waveform.  (4) $B / A = B \div A \times 100$ $C / A = C \div A \times 100$
11	AFT Center Voltage	b	ON	OFF or ON	ON	b	(1) Apply 5V to TP7. (2) Measure the TP43 voltage with SW3 off ($V_{43(0)}$). (3) Measure the TP43 voltage with SW3 on (V_{43MUTE}). $\Delta V_{43} = V_{43(0)} - V_{43MUTE}$
12	Intermodulation	b	ON	OFF	ON	b	(1) From TP8, input a signal composed of the following. SG1 : $38.9MHz$ $84dB\mu V$ SG2 : $34.47MHz$ $78dB\mu V$ SG3 : $33.4MHz$ $78dB\mu V$ (2) Adjust the voltage to TP7 so that the lowest level output at TP43 is 2.4V. (3) Measure the difference between the 4.43MHz and 1.07MHz components in the TP43 output.
13	Input Impedance	b	ON	OFF	ON	b	(1) Apply 5V to TP7. (2) Measure the impedance between pin 9 and GND, and the impedance between pin 10 and GND.

SIF stage

NOTE	ITEM	TEST CONDITIONS (UNLESS OTHERWISE SPECIFIED $V_{CC} = 9V$, $T_a = 25 \pm 3^\circ C$)					TEST METHOD
		SW & VR MODES					
		SW1	SW2	SW3	SW4	SW5	
14	FM Detection Output Level	b	ON	OFF	OFF	b	(1) From TP49, input the following signal : $f_0 = 5.5MHz$, $100dB_{\mu V}$, $400Hz$, $25kHz$ devi FM. (2) Measure the TP3 output level.
15	Input Limiting Sensitivity	b	ON	OFF	OFF	b	(1) From TP49, input the following signal : $f_0 = 5.5MHz$, $100dB_{\mu V}$, $400Hz$, $25kHz$, devi FM. (2) Lower the input level and measure the input level when the TP3 output level drops to $-3dB$ of V_{OD} .
16	AM Rejection Ratio	b	ON	OFF	OFF	b	(1) From TP49, input $f_0 = 5.5MHz$. FM : $400Hz$ $25kHz$ devi AM : $400Hz$ 30% , input level $100dB_{\mu V}$ (2) Measure the FM and AM output levels at TP3. $AMR = 20\log (FM / AM)$
17	Band Width (3dB)	b	ON	OFF	OFF	b	(1) From TP44, input the signal : $f_0 = 5.5MHz$, $100dB_{\mu V}$, $400Hz$ $25kHz$ devi FM. (2) Vary the input signal frequency (f_0), measuring this frequency when the TP3 output drops to $-3dB$ of V_{OD} .
18	THD Band Width (1.5%)	b	ON	OFF	OFF	b	(1) From TP49, input the signal : $f_0 = 5.5MHz$, $100dB_{\mu V}$, $400Hz$ $25kHz$ /devi FM. (2) Vary the input signal frequency (f_0), and measure this frequency when the TP3 output signal distortion rate reaches 1.5% .
19	ATT AC Gain	a	ON	OFF	ON	c	(1) From TP1, input a $1kHz$, $1V_{p-p}$ signal. (2) Apply $5.0V$ to TP50. (3) Determine the TP2 output level (V_{2ATT}). $G_{ATT} = 20\log (V_{2ATT} / 1.0)$
20	ATT Max. Attenuation Volume	a	ON	OFF	ON	c	(1) From TP1, input a $1kHz$ signal. (2) Apply $5.0V$ to TP50. Adjust the input signal level so that the TP2 output level is $1V_{p-p}$. (3) Apply $0V$ to TP50, and measure the TP2 output level (V_{2min}). $G_{ATTmax} = 20\log (V_{2min} / 1.0)$
21	AF Amp AC Gain	b	ON	OFF	ON	a	(1) From TP2A, input a $1kHz$, $0.1V_{p-p}$ signal. (2) Measure the TP53 output level (V_{p53}). $G_{VAF} = 20\log (V_{p53} / 0.1)$

Video stage

NOTE	ITEM	TEST CONDITIONS (UNLESS OTHERWISE SPECIFIED $V_{CC} = 9V$, $T_a = 25 \pm 3^\circ C$)					
		SW & VR MODES					TEST METHOD
		SW 14	VR3	VR4	VR2		
22	Y Input Impedance	OFF	MIN	CNT	CNT		(1) To pin 31, apply a $1V_{p-p}$, 1kHz signal via $10k\Omega$. (2) Measure the TP31 signal amplitude (V_{31}). (3) $INP = V_{31} \times 10^4 / (1.0 - V_{31})$
23	SHR Input Impedance	OFF	CNT	CNT	CNT		(1) To pin 33, apply a $0.1V_{p-p}$, 2.4MHz signal via $10k\Omega$. (2) Measure the pin 33 signal amplitude (V_{33}). (3) $INP_{SHR} = V_{33} \times 10^4 / (0.1 - V_{33})$
24	Y Input Dynamic Range	ON	CNT	ADJ	MIN		(1) Adjust VR4 so that the picture period voltage on T19 is 4.5V. (2) Measure the DC voltage on TP15 (V_{15}). (3) Add DC voltage V_{15} to TP15. (4) Connect an external power supply to pin 31 and change the DC voltage. (5) Measure the pin 31 input voltage at 10% of the total TP19 voltage range swing (V_{di1}), and the pin 31 input voltage at 90% of the range (V_{di2}). $D_{ynY} = V_{di1} - V_{di2}$
25	SHR Input Dynamic Range	OFF	MAX	ADJ	CNT		(1) Adjust VR4 so that the picture period voltage on T19 is 4.5V. (2) Input a 2.4MHz signal from TP33. (3) When changing the input signal amplitude, measure this amplitude at the start of saturation of the TP19 output.
26	Max. Video Output Level Min. Video Output Level	ON	CNT	ADJ	MAX		(1) Adjust VR4 so that the picture period voltage on T19 is 4.5V. (2) Measure the voltage on TP15 (V_{15}). (3) Apply V_{15} to TP15. (4) Connect an external power supply to pin 31 and change the voltage. (5) Measure the maximum and minimum TP19 output voltages.
27	Video Output Drive Current	OFF	CNT	ADJ	CNT		(1) Adjust VR4 so that the picture period voltage on T19 is 4.5V. (2) Connect TP19 to the V_{CC} via $1k\Omega$. (3) Measure the TP19 picture period voltage (V_{19}). $Y_{ISINK} = (V_{CC} - V_{19}) / 1 \text{ (mA)}$

NOTE	ITEM	TEST CONDITIONS (UNLESS OTHERWISE SPECIFIED $V_{CC} = 9V$, $T_a = 25 \pm 3^\circ C$)					
		SW & VR MODES					TEST METHOD
		SW 14	VR3	VR4	VR2		
28	Video AC Gain	OFF	CNT	ADJ	MAX		(1) Adjust VR4 so that the picture period voltage on T19 is 4.5V. (2) Input a 100kHz, $1V_{p-p}$ signal to TP31. (3) Measure the TP19 output signal amplitude (V_{19}). $G_Y = 20 \log (V_{19} / 1)$ (dB)
29	SHR AC Gain	OFF	MAX	ADJ	MAX		(1) Adjust VR4 so that the picture period voltage on T19 is 4.5V. (2) Input a 2.4MHz, $0.1V_{p-p}$ signal to TP33. (3) Measure the TP19 output signal amplitude (V_{19}). $G_{SHR} = 20 \log (V_{19} / 0.1)$ (dB)
30	Video Frequency Characteristic	OFF	CNT	ADJ	MAX		(1) Adjust VR4 so that the picture period voltage on T19 is 4.5V. (2) Input a 100kHz, $1V_{p-p}$ signal to TP31. (3) Measure the TP19 output signal amplitude (V_{19}). (4) Change the input signal frequency, and measure the input signal frequency when the TP19 output level drops to $-3dB$ of V_{19} .
31	Brightness Control Sensitivity	OFF	CNT	ADJ	CNT		(1) Adjust VR4 so that the picture period voltage on T19 is 4.5V. (2) Adjust VR4 to increase the TP34 voltage by 0.5V. (3) Measure the TP19 output voltage (V_{19}). $GBRT = (V_{19} - 4.5) \times 2$
32	Brightness Control Voltage	OFF	CNT	ADJ	CNT		(1) Adjust VR4 so that the picture period voltage on T19 is 4.5V. (2) Measure the TP34 voltage.
33	DC Restoration	OFF	CNT	ADJ	CNT		(1) Adjust VR4 so that the picture period voltage on T19 is 4.5V. (2) From TP31, input a $1V_{p-p}$ signal with 100% APL. (3) Monitoring in TP19 oscilloscope AC mode, measure the TP19 black level fluctuation when the input signal APL changes from 100% to 0% (V_{AC}). (4) Set the oscilloscope to DC mode, and measure the black level fluctuation as above (V_{DC}). $T_{DC} = (1 - V_{DC} / V_{AC}) \times 100$

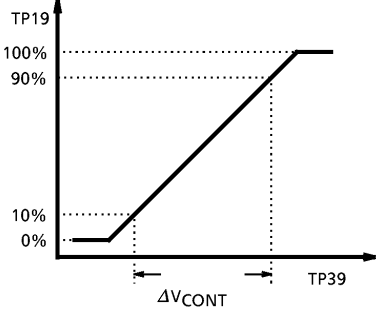
NOTE	ITEM	TEST CONDITIONS (UNLESS OTHERWISE SPECIFIED $V_{CC} = 9V$, $T_a = 25 \pm 3^\circ C$)					TEST METHOD
		SW & VR MODES					
		SW 14	VR3	VR4	VR2		
34	Clamp Terminal Voltage	OFF	CNT	ADJ	CNT		(1) Adjust VR4 so that the picture period voltage on T19 is 4.5V. (2) Measure the TP15 DC voltage.
35	Contrast Control Voltage Contrast Gain Variable Range	OFF	CNT	ADJ	ADJ		(1) Adjust VR4 so that the picture period voltage on T19 is 4.5V. (2) Input a 100kHz, 0.5V _{p-p} signal to TP31. (3) Adjust VR2 from maximum to minimum. When at maximum, the TP19 output signal amplitude is 100% ; at minimum, 0%. Measure the voltages on TP39 at 90% and 10%.  (4) With VR2 at maximum then minimum, measure the TP19 output signal levels (V_{MAX} and V_{MIN}). $\Delta G_{CONT} = 20 \log (V_{MAX} / V_{MIN})$
36	Frequency Response Dependence on Contrast Control	OFF	CNT	ADJ	ADJ		(1) Adjust VR4 so that the picture period voltage on T19 is 4.5V. (2) To pin TP31, input 100kHz and 4MHz signals, both with amplitude of 1V _{p-p} . (3) With VR4 at maximum then minimum, measure the TP19 output signal levels (V_{MAX} and V_{MIN}). $\Delta G_{fCONT} = 20 \log (V_{MAX}^{4MHz} / V_{MAX}^{100kHz}) - 20 \log (V_{MIN}^{4MHz} / V_{MIN}^{100kHz})$

NOTE	ITEM	TEST CONDITIONS (UNLESS OTHERWISE SPECIFIED $V_{CC} = 9V$, $T_a = 25 \pm 3^\circ C$)					TEST METHOD
		SW & VR MODES					
		SW 14	VR3	VR4	VR2		
37	Picture Control Gain Range	OFF	ADJ	ADJ	CNT		(1) Adjust VR4 so that the picture period voltage on T19 is 4.5V. (2) Input a 2.4MHz, 0.1V _{p-p} signal to pin TP33. (3) With VR3 at maximum then minimum, measure the TP19 output signal levels (V_{MAX} and V_{MIN}). $\Delta G_{SHR} = 20 \log (V_{MAX} / V_{MIN})$
38	Picture Control Voltage Range	OFF	ADJ	ADJ	CNT		(1) Adjust VR4 so that the picture period voltage on T19 is 4.5V. (2) Input a 2.4MHz, 0.1V _{p-p} signal to pin TP33. (3) Adjust VR3 from maximum to minimum. When at maximum, the TP33 output signal amplitude is 100% ; at minimum, 0%. Measure the voltages on TP33 at 90% and 10%. <div style="text-align: center;"> <p>The graph plots TP19 output signal level on the y-axis (0% to 100%) against TP33 input signal amplitude on the x-axis. A solid line shows a linear increase from 0% at 0% input to 100% at 100% input. Dotted lines indicate that at 90% input, the output is 90%, and at 10% input, the output is 10%. The horizontal distance between the 10% and 90% input points is labeled ΔV_{SHR}.</p> </div>
39	V-BLK Pulse Output Level H-BLK Pulse Output Level V-BLK Pulse Width (50Hz) V-BLK Pulse Width (60Hz)	OFF	CNT	ADJ	CNT		(1) Adjust VR4 so that the picture period voltage on T19 is 4.5V. (2) Measure TP19 using an oscilloscope. (3) Measure the vertical and the horizontal blanking period voltages. (4) Measure the vertical blanking pulse width. (5) Monitor TP21 using an oscilloscope. Measure the TP19 horizontal blanking pulse delay in relation to TP21. <div style="text-align: center;"> <p>The diagram shows two waveforms: TP19 (top) and TP21 (bottom). TP19 is a square wave pulse. TP21 is a square wave pulse that starts after TP19. The time interval between the leading edges of TP19 and TP21 is labeled t_{DBS}.</p> </div>

Chroma stage

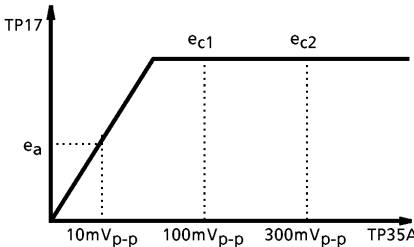
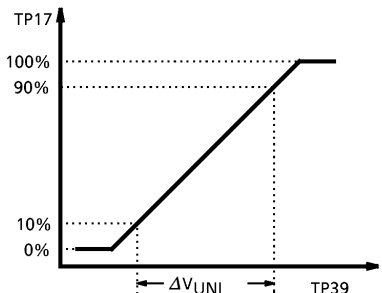
NOTE	ITEM	TEST CONDITIONS (UNLESS OTHERWISE SPECIFIED $V_{CC} = 9V$, $T_a = 25 \pm 3^\circ C$)									
		SW & VR MODES									TEST METHOD
		SW 32	SW 10	SW 33	SW 30	SW 37	VR1	VR2	VR5		
40	ACC Characteristic	ON	OFF	ON	a	OFF	MIN	MIN	CNT	(1) From TP35A, input a burst cross = 1 : 2.25 signal. (2) Measure the TP17 output signal amplitude with burst levels of $10mV_{p-p}$, $100mV_{p-p}$, and $300mV_{p-p}$.  $A = e_{c2} / e_{c1}$	
41	Unicolor Control Voltage Range Unicolor Control Gain Range	ON	OFF	ON	a	OFF	CNT	ADJ	CNT	(1) Input a $150mV_{p-p}$ chroma signal from TP35A. (2) Adjust VR2 from maximum to minimum (V_{17MAX} and V_{17MIN}). When at maximum, the TP19 output signal amplitude is 100% ; at minimum, 0%. Measure the voltages on TP39 at 90% and 10%.  $\Delta G_{UNI} = 20 \log (V_{17MAX} / V_{17MIN})$	

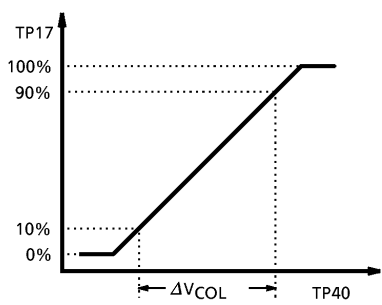
NOTE	ITEM	TEST CONDITIONS (UNLESS OTHERWISE SPECIFIED $V_{CC} = 9V$, $T_a = 25 \pm 3^\circ C$)									
		SW & VR MODES									TEST METHOD
		SW 32	SW 10	SW 33	SW 30	SW 37	VR1	VR2	VR5		
42	Unicolor Control Phase Change	ON	OFF	ON	a	OFF	CNT	ADJ	CNT	(1) Input a 150mV _{p-p} chroma signal from TP35A. (2) Monitoring TP17, vary VR2 and measure the phase change when the level at TP17 drops by 20dB.	
43	Color Control Voltage Range Color Control Gain Range	ON	OFF	ON	a	OFF	ADJ	CNT	CNT	(1) Input a 150mV _{p-p} chroma signal from TP35A. (2) Adjust VR1 from maximum to minimum. When at maximum, the TP16 output signal amplitude is 100% ; at minimum, 0% (V_{17MAX} and V_{17MIN}). Measure the voltages on TP40 at 90% and 10%.  $\Delta G_{COL} = 20 \log (V_{17MAX} / V_{17MIN})$	
44	Color Control Phase Change	ON	OFF	ON	a	OFF	ADJ	CNT	CNT	(1) Input a 150mV _{p-p} chroma signal from TP35A. (2) Monitoring TP17, vary VR1 and measure the phase change when the level at TP17 drops by 20dB.	
45	Color Control Residual	ON	OFF	ON	a	OFF	MIN	MAX	CNT	(1) Input a 150mV _{p-p} chroma signal from TP35A. (2) Adjust VR1 to minimum, and measure the TP17 output signal amplitude.	

NOTE	ITEM	TEST CONDITIONS (UNLESS OTHERWISE SPECIFIED $V_{CC} = 9V$, $T_a = 25 \pm 3^\circ C$)								TEST METHOD
		SW & VR MODES								
		SW 32	SW 10	SW 33	SW 30	SW 37	VR1	VR2	VR5	
46	Tint Control Voltage Range Tint Control Phase Range	ON	OFF	ON	a	OFF	CNT	CNT	ADJ	(1) Input a $150mV_{p-p}$ chroma signal from TP35A. (2) Adjust VR5 from maximum to minimum. When at maximum, the TP17 output signal amplitude is 100% (θ_1); at minimum, 0% (θ_2). Measure the voltages on TP32 at 90% and 10%.
47	PAL / NTSC SW Voltage	OFF	OFF	ON	a	OFF	CNT	CNT	CNT	(1) Input a $150mV_{p-p}$ chroma signal from TP35A. (2) Lower the TP32 voltage. Measure the TP32 voltage when the mode switches from NTSC to PAL.
48	Killer Sensitivity	ON	OFF	ON	a	OFF	CNT	CNT	CNT	(1) Input a $150mV_{p-p}$ chroma signal from TP35A. (2) Attenuate the burst level of the input signal, and measure the burst level when the TP40 voltage goes low.
49	Killer Voltage	ON	OFF	ON	b	ON	CNT	CNT	CNT	(1) Set the TP35A input to zero. (2) Vary the TP42 voltage, and measure the TP42 voltage when the TP40 voltage goes low.

NOTE	ITEM	TEST CONDITIONS (UNLESS OTHERWISE SPECIFIED $V_{CC} = 9V$, $T_a = 25 \pm 3^\circ C$)								
		SW & VR MODES								TEST METHOD
		SW 32	SW 10	SW 33	SW 30	SW 37	VR1	VR2	VR5	
50	Ident Sensitivity	ON	OFF	ON	a	OFF	CNT	CNT	CNT	(1) Input a 150mV _{p-p} chroma signal from TP35A. (2) Attenuate the burst level of the input signal, and measure the burst level when the ID malfunction starts.
51	Ident Voltage	ON	OFF	ON	b	ON	CNT	CNT	CNT	(1) Set the TP35A input to zero. (2) Vary the TP42 voltage, monitor TP11, and measure the TP42 voltage when the sweep begins.
52	APC Pull-In Range APC Hold Range	ON	OFF	ON	a	OFF	CNT	CNT	CNT	(1) Input a 4.43MHz, 100mV _{p-p} signal from TP35A. (2) Monitoring TP40, vary the input signal frequency and measure the input signal frequencies when the TP40 voltage goes high (f_{pH} , f_{pL}). $\Delta f_{pH} = f_{pH} - 4433619$ (Hz) $\Delta f_{pL} = 4433619 - f_{pL}$ (Hz) (3) Measure the input signal frequencies when the TP40 voltage goes low (f_{HH} , f_{HL}). $\Delta f_{HH} = f_{HH} - 4433619$ (Hz) $\Delta f_{HL} = 4433619 - f_{HL}$ (Hz)
53	Frequency Sensitivity	ON	OFF	ON	b	ON	CNT	CNT	CNT	(1) Set the TP35A input to zero, killer off. (2) Measure the TP14 oscillation frequency. (3) Vary the TP11 voltage, and measure the TP11 voltage when the oscillation frequency at TP14 is f_{SC} (V_{11}). (4) Measure the TP14 Δf when adding $V_{11} \pm 200mV$ to TP11. $\beta = \Delta f / 400mV$

NOTE	ITEM	TEST CONDITIONS (UNLESS OTHERWISE SPECIFIED $V_{CC} = 9V$, $T_a = 25 \pm 3^\circ C$)								
		SW & VR MODES								TEST METHOD
		SW 32	SW 10	SW 33	SW 30	SW 37	VR1	VR2	VR5	
54	Demodulation Color Differential Output	ON	OFF	ON	a	OFF	MAX	MAX	CNT	(1) Input a $100mV_{p-p}$ chroma signal (rainbow color) to TP35A. (2) Measure the output signal amplitudes of TP16, TP17, and TP18.
55	Max. Demodulation Color Differential Output	ON	ON	ON	a	ON	MAX	MAX	CNT	(1) Input a 4.433619MHz, $100mV_{p-p}$ signal to TP35A. (2) Killer off (3) Vary the TP11 voltage so that the oscillation frequency of TP14 is 4.433619MHz. (4) Measure the output signal amplitude of TP16, TP17, and TP18.
56	Demodulation Relative Amplitude Demodulation Relative Phase	ON	ON	ON	a	ON	CNT	CNT	CNT	(1) Input a 4.433619MHz, $100mV_{p-p}$ signal to TP35A. (2) Killer off (3) Vary the TP11 voltage so that the oscillation frequency of TP14 is 4.433619MHz. (4) Measure the output amplitude ratios of TP16, TP17, and TP18 (V_R/V_B and V_G/V_B). (5) Measure the relative phase differences of the 10kHz signals output from TP16, TP17, and TP18 (θ_{R-B} , θ_{G-B}).
57	Demodulation Output Residual carrier Demodulation Output Residual harmonic	ON	ON	ON	a	ON	CNT	CNT	CNT	(1) Set the TP35A input to zero. (2) Killer off (3) Vary the voltage on TP11 so that the TP14 oscillation frequency is 4.433619MHz (f_{sc}). (4) Measure the f_{sc} leakages of TP16, TP17, and TP18. (5) Likewise, measure the f_{sc} harmonics.

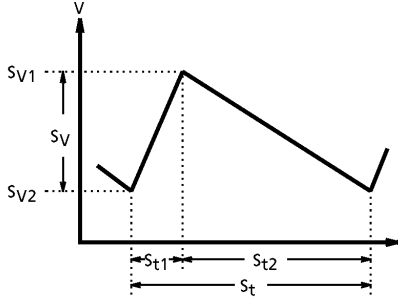
NOTE	ITEM	TEST CONDITIONS (UNLESS OTHERWISE SPECIFIED $V_{CC} = 9V$, $T_a = 25 \pm 3^\circ C$)								TEST METHOD
		SW & VR MODES								
		SW 32	SW 10	SW 33	SW 30	SW 37	VR1	VR2	VR5	
58	Demodulation Output Band Width	ON	OFF	ON	a	ON	CNT	CNT	CNT	(1) Input a 4.433619MHz, 100mV _{p-p} signal from TP35A. (2) Killer off (3) Vary the voltage on TP11 so that the TP14 oscillation frequency is 4.433619MHz (f_{sc}). (4) Measure the output amplitude of TP16, TP17, and TP18, and set them to 0dB. (5) Vary the input frequency, and measure the input frequency when the color difference output drops to -3dB (f_{IN}). $f_{DEMO} = f_{IN} - f_{sc} $ (Hz)
59	Demo. Voltage Difference	ON	OFF	ON	a	OFF	MIN	MIN	CNT	(1) Input a 100mV _{p-p} chroma signal from TP35A. (2) Measure the DC differential voltages of TP16, TP17, and TP18.
60	D.L. AMP. Characteristic	ON	OFF	OFF	a	OFF	CNT	CNT	CNT	(1) From TP35A, input a 100mV _{p-p} chroma (burst) signal with a burst / chroma ratio of 1 : 2. (2) Measure the TP38 output signal amplitude.
61	Sweeper Amplitude Sweeper Period	ON	OFF	ON	a	OFF	CNT	CNT	CNT	(1) Set the TP35A input to zero. (2) Monitor the TP11 waveform.  (3) Measure the sweep amplitude and the sweep cycle.

Deflection stage

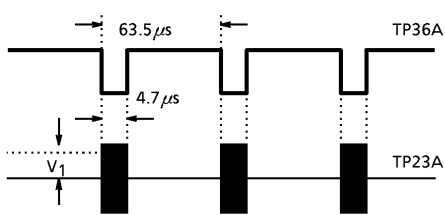
NOTE	ITEM	TEST CONDITIONS (UNLESS OTHERWISE SPECIFIED $V_{CC} = 9V$, $T_a = 25 \pm 3^\circ C$)			TEST METHOD
		SW & VR MODES			
		SW 22	SW 24		
62	Sync. Sepa. Sense Current	ON	ON		(1) Connect an external power supply to TP36B via an ammeter. (2) Decrease the external power supply voltage from 3V, and read the ammeter when the vertical output cycle of TP30 reduces from 353H, to 268.5H.
63	H.AFC Detection Current	OFF	ON		(1) Set the external power supply to the pin 23 voltage when the pin is open, and connect to TP23B. (2) Input the signal shown below to TP36A. (3) Monitor TP23A and calculate the current from the data in the diagram below. $I_{DET} = V_1 \text{ (mV)} / 1 \text{ (k}\Omega\text{)} \text{ (mA)}$ 
64	H.AFC Detection Stop Period	ON	ON		(1) Input a 2V _{p-p} composite video signal to TP36A. (2) Monitor TP23A and measure the period between signal spikes.
65	32f _H VCO Oscillation Starting Voltage H.OUT Starting Voltage	ON	OFF		(1) Do not connect V_{CC} to pin 12. (2) Connect an external power supply to TP25 and increase the voltage from 2V. (3) Measure the voltage when an oscillation waveform occurs at TP24. (4) Measure the voltage when horizontal output occurs at TP21.
66	Horizontal Free-Run Frequency	ON	ON		(1) Measure the frequency of the horizontal output that occurs at TP22.

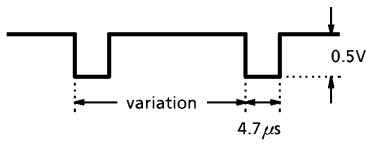
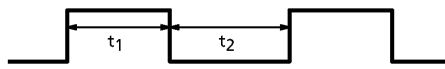
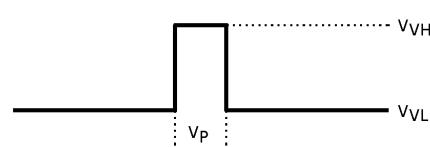
NOTE	ITEM	TEST CONDITIONS (UNLESS OTHERWISE SPECIFIED $V_{CC} = 9V$, $T_a = 25 \pm 3^\circ C$)			TEST METHOD
		SW & VR MODES			
		SW 22	SW 24		
67	Horizontal Pull-In Range Horizontal Hold Range	ON	ON		 <p>(1) Apply the following signal to TP36A. (2) Monitor TP36A and TP21. (3) Measure the lock-in frequency range, in which the frequency is locked when the frequency of the above signal is varied (Δf_{HPULL}). (4) Likewise, measure the retention frequency range, in which the frequency is lost (Δf_{HHOLD}).</p>
68	Hor. OSC. Control Sensitivity	ON	ON		<p>(1) Measure the TP22 frequency change when the TP23A voltage changes by $\pm 0.05V$ from the voltage with a horizontal oscillation frequency of 15625Hz.</p>
69	Hor. Output Pulse Duty	ON	ON		<p>(1) Monitor the TP22 output waveform.</p>  <p>$T = t_1 / (t_1 + t_2) \times 100 (\%)$</p>
70	X-ray Protector Sense Voltage X-ray Protector Hold Voltage	ON	ON or OFF		<p>(1) Apply voltage to TP20, and measure the TP20 voltage when the TP22 output disappears (becoming low level). (2) SW24 : off (3) After applying 2.5V to TP25, check that TP22 is at low level when the voltage is increased to 9V.</p>
71	Horizontal Output Voltage	ON	ON		<p>(1) Measure the high-level voltage and low-level voltage on the waveform output from TP22.</p>
72	Vertical Pulse Width Vertical Output Voltage	ON	ON		 <p>(2) Measure V_p, V_{VH}, and V_{VL}.</p>

NOTE	ITEM	TEST CONDITIONS (UNLESS OTHERWISE SPECIFIED $V_{CC} = 9V$, $T_a = 25 \pm 3^\circ C$)			TEST METHOD
		SW & VR MODES			
		SW 22	SW 24		
73	Vertical Pull-In Range	ON	ON		(1) Input a $2V_{p-p}$ composite video signal to TP36A. (2) Change the V sync. frequency of the composite video signal, and measure the V sync. frequency range where the V output is locked.
74	Ver. Free-Run Frequency	ON	ON		(1) Apply voltage to TP23A so that the frequency of the signal output from TP22 is 15625Hz. (2) Measure the frequency of the signal output from TP30.
75	50Hz / 60Hz Switching Voltage 50Hz / 60Hz Detection Voltage	ON	ON		(1) Apply external voltage to TP41, and measure the voltages at TP41 and TP35 when the TP30 output signal cycle changes from 297H to 353H. (2) Likewise, measure the voltage on TP41 and TP35 when the TP30 output signal cycle changes from 353H to 297H.

OSD stage

NOTE	ITEM	TEST CONDITIONS (UNLESS OTHERWISE SPECIFIED $V_{CC} = 9V$, $T_a = 25 \pm 3^\circ C$)					TEST METHOD
		SW & VR MODES					
		VR4	VR6	SW 26	SW 27	SW 28	
76	OSD Input ON Current	CNT	CNT	OFF	OFF	OFF	(1) Apply 5V externally to TP26. (2) Lower the external voltage, and measure the current output from TP26 when the voltage output from TP16 goes high. (3) Perform the same measurement at TP27 and TP28.
77	OSD Input OFF Current	CNT	CNT	OFF	OFF	OFF	(1) Apply externally 0V to TP26. (2) Increase the external voltage, and measure the current output from TP26 when the voltage output from TP16 goes low. (3) Perform the same measurement at TP27 and TP28.
78	OSD Output HIGH Level	CNT	CNT	ON	ON	ON	(1) Turn SW26 on. (2) Measure the TP16 output voltage. (3) Perform the same measurement at TP17 and TP18.
79	OSD Output LOW Level	CNT	CNT	ON or OFF	ON or OFF	ON or OFF	(1) Turn SW26 on, and SW27 and SW28 off. (2) Measure the TP17 and TP18 output voltages. (3) Perform the same measurement for B and G.
80	Output Rise Time Rise Propagation Delay Time Output Fall Time Fall Propagation Delay Time	CNT	CNT	OFF	OFF	OFF	(1) Input signal (a) shown below to TP26. (2) Monitoring TP16, TP17, and TP18, measure τ_R , t_{pR} , τ_F , and t_{pF} as shown in (b) in the diagram below. (3) Perform the same measurements for TP27 and TP28.

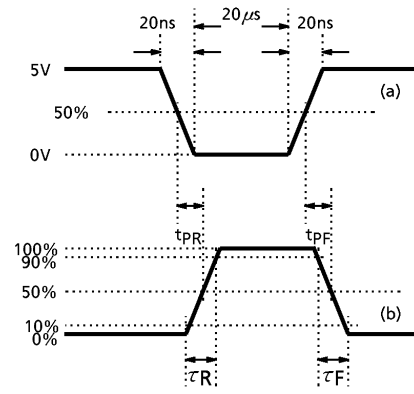

NOTE	ITEM	TEST CONDITIONS (UNLESS OTHERWISE SPECIFIED $V_{CC} = 9V$, $T_a = 25 \pm 3^\circ C$)					TEST METHOD
		SW & VR MODES					
		VR4	VR6	SW 26	SW 27	SW 28	
81	Y→OSD Switching Time Y→OSD Switching Delay Time OSD→Y Switching Time OSD→Y Switching Delay Time	ADJ	ADJ	OFF	OFF	OFF	(1) Adjust VR4 so that the T19 output voltage is 5V. (2) Input signal (a) shown below to TP26. (3) Adjust VR6 so that the T19 output voltage with OSD on is 4V. (4) Monitoring TP19, measure τ_{Y-O} , t_{Y-O} , τ_{O-Y} , and t_{O-Y} as shown in (b) in the diagram below.
82	OSD Brightness Control Voltage OSD Brightness Sensitivity	CNT	ADJ	ON	ON	ON	(1) Adjust VR6 so that the TP19 output voltage is 4V. (2) Measure the voltage on TP54. (3) Measure the TP19 fluctuation when changing the TP54 voltage $\pm 0.5V$ (ΔV_{19}). $G_{OSDBRT} = \Delta V_{19} / 1$

TEST CIRCUIT 1
PIF/SIF

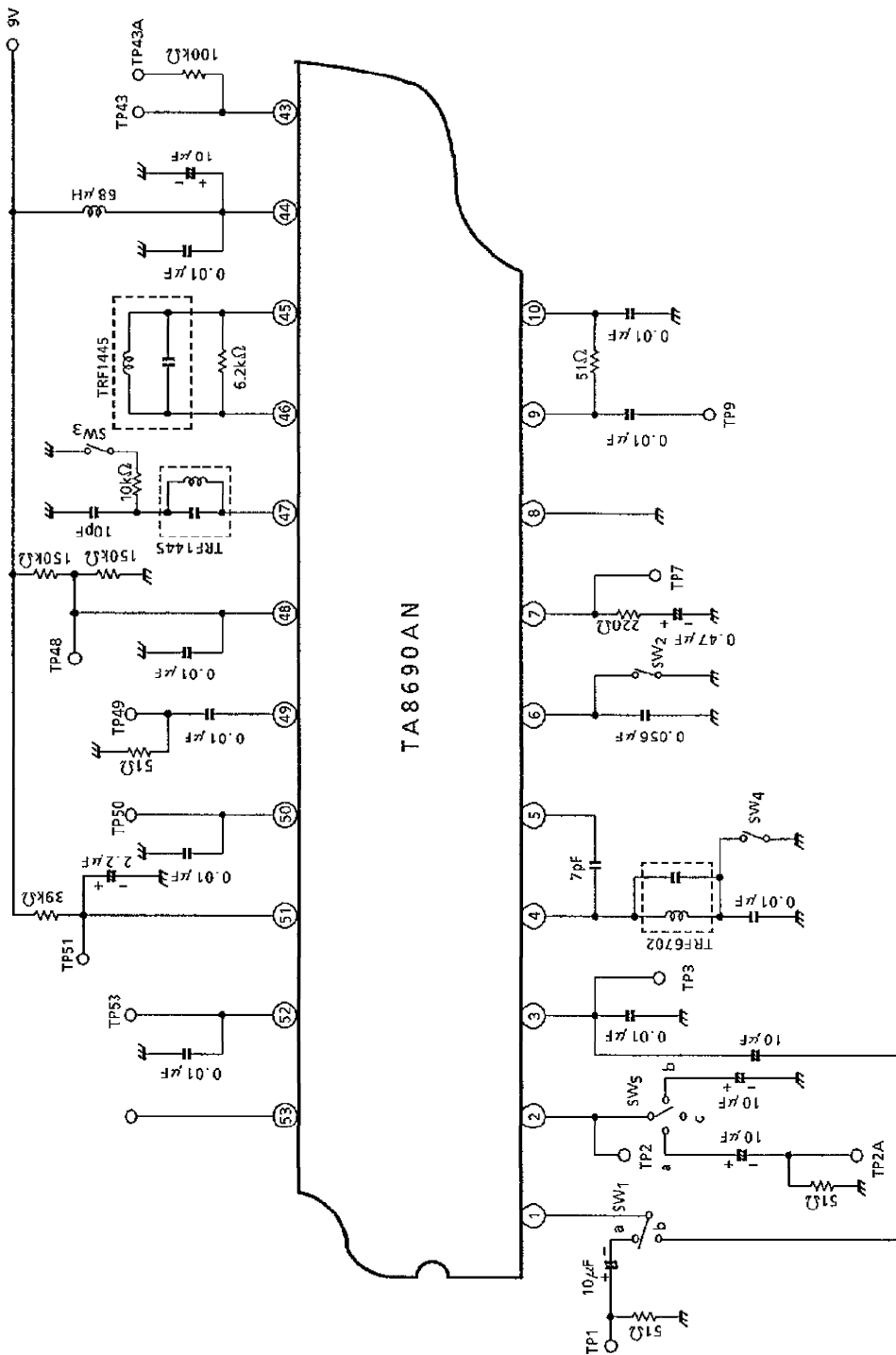

TA8690AN - 40

TEST CIRCUIT 2
Video

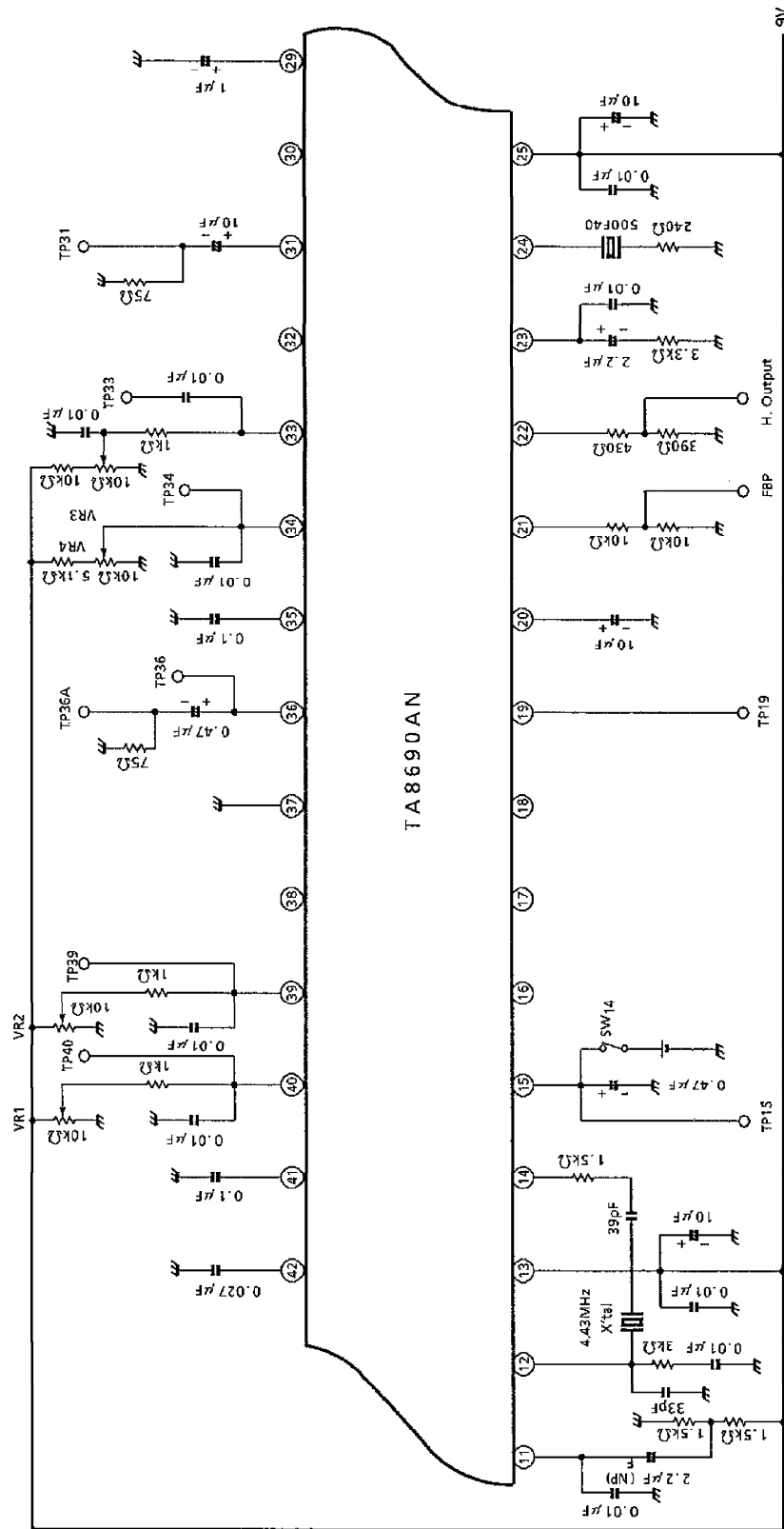

TA8690AN - 41

TEST CIRCUIT 3
 Chroma

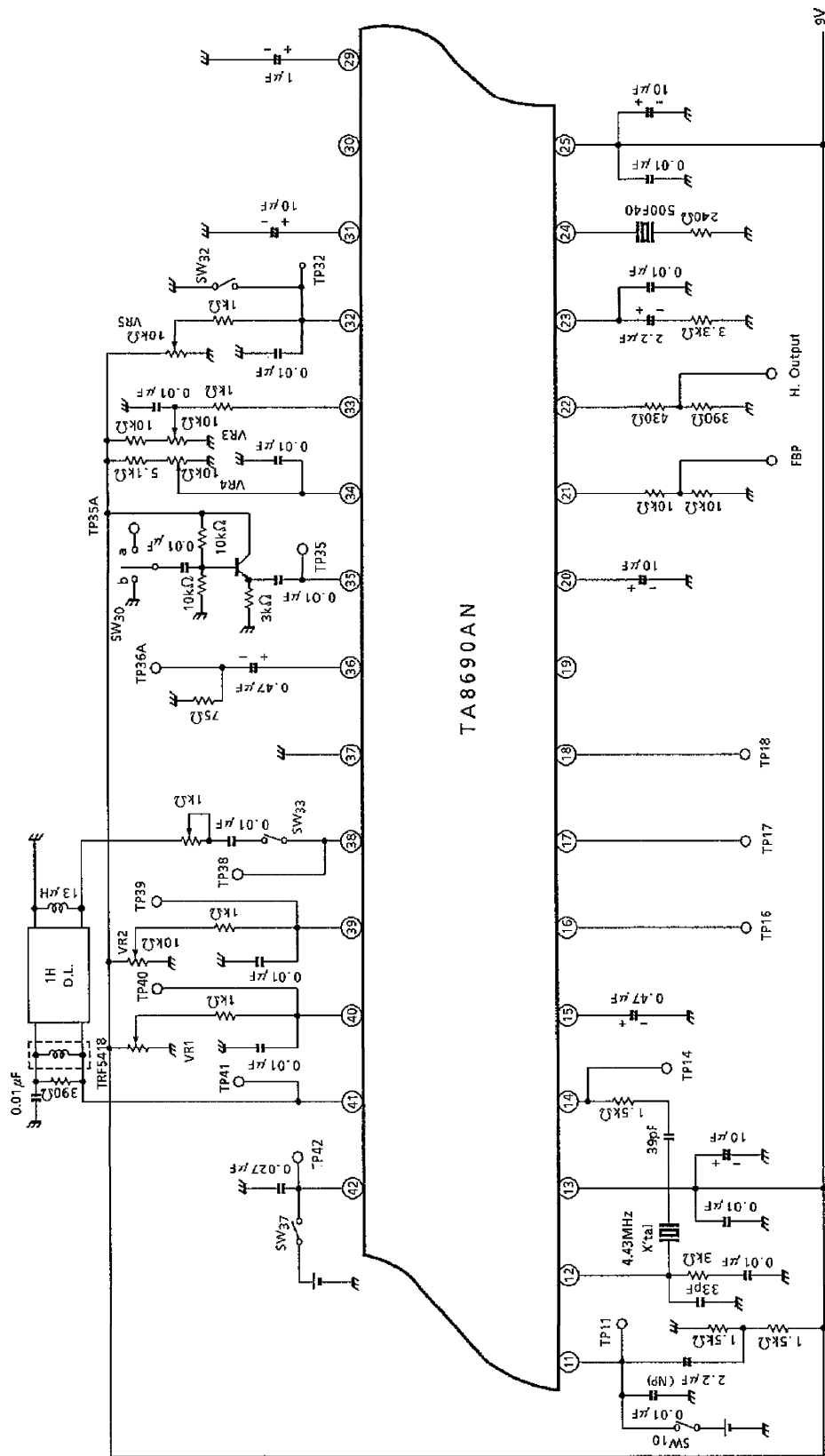

TA8690AN-42

TEST CIRCUIT 4
Deflection

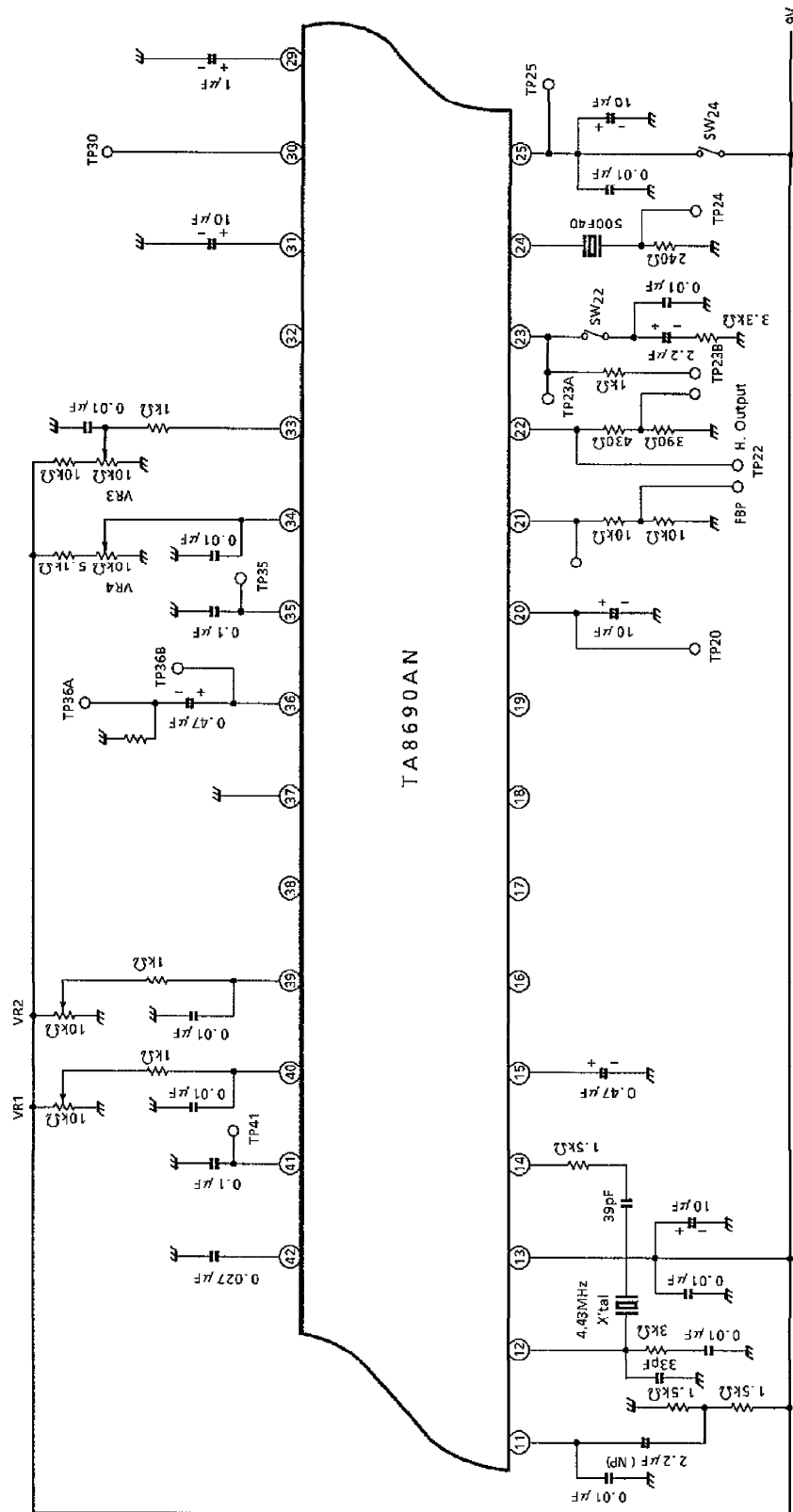

TA8690AN - 43

TEST CIRCUIT 5
OSD

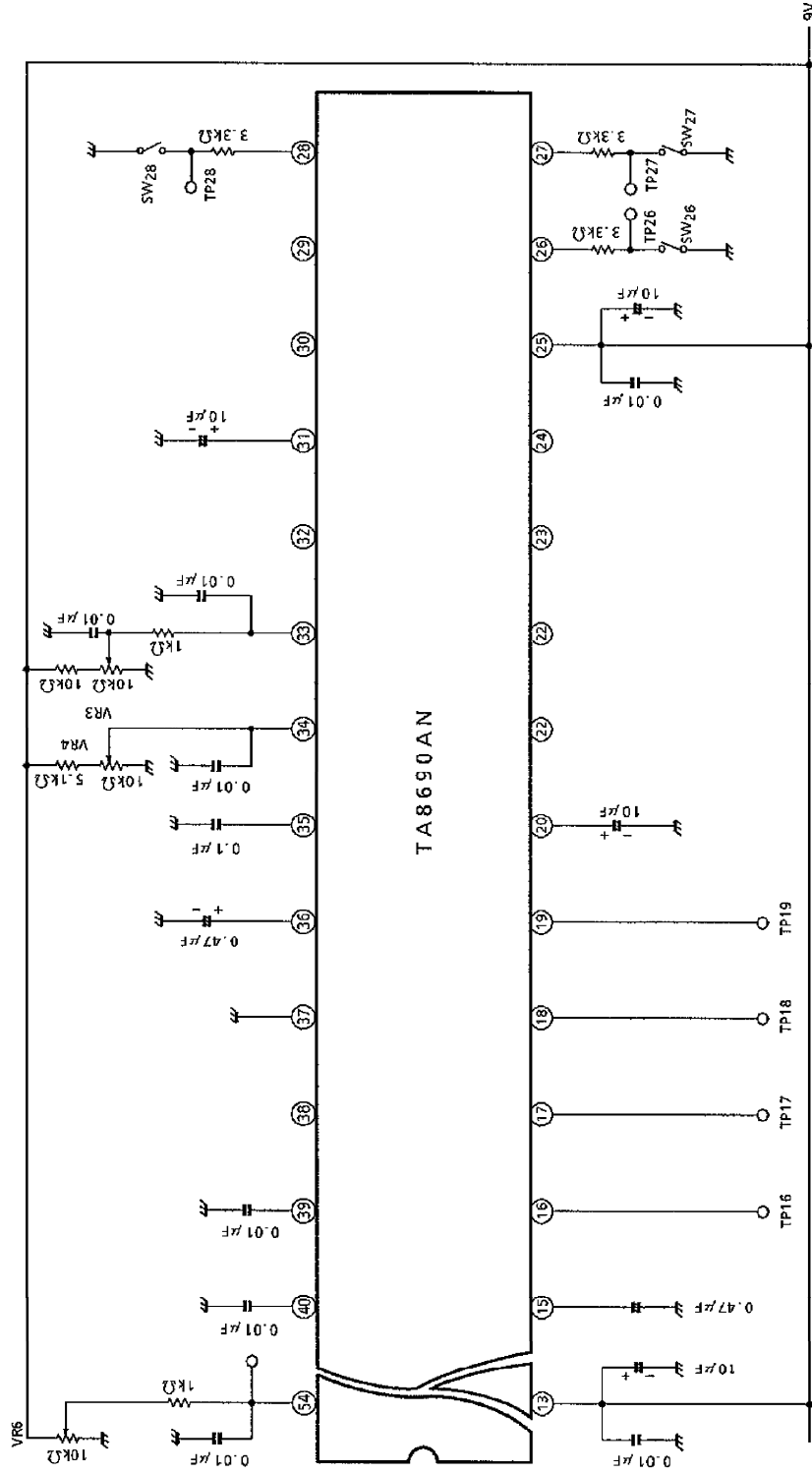

TA8690AN - 44

SPECIAL COMPONENT DATA

Coil

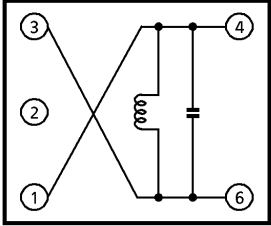
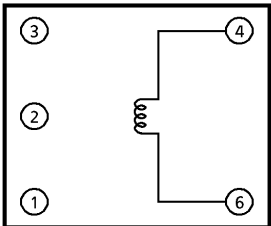
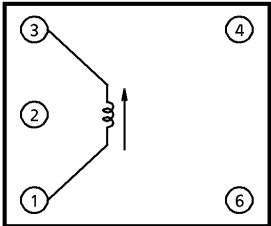
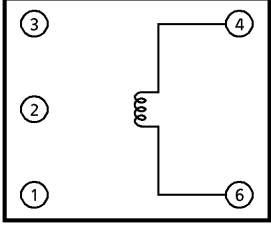
COMPO- NENT	USE	SIZE	CONNECTION DIAGRAM (BOTTOM VIEW)	ELECTRICAL SPECS.
TRF-1445D	PIF AFT	10mm		f_{oMAX} : 46.0MHz - 8% or higher (supplementary coil 30~100MHz) f_{oMIN} : 35.5MHz + 8% or lower (supplementary coil 30~100MHz) No load Q : $65 \pm 25\%$ (at f_{oMIN}) Built-in C : PH1H750J Coil : $0.45\phi, 6 \frac{1}{4}t$
TRF-6702D	SIF	10mm		Nominal center frequency : 4.5~6.5MHz Inductance C_{MAX} : 160.1pF (STD) - 10% or higher C_{MIN} : 95.3pF (STD) + 10% or lower No load Q : $48 \pm 20\%$ (at 4.5MHz) Coil : $0.1\phi, 50t$ (*) Set the center frequency using external capacitor C.
TRF-5418	Matching coil for 1HDL	10mm		L_{min} : $5.2\mu H$ or lower L_{max} : $12.2\mu H$ or higher $Q = 57$ (at $L = 8.6\mu H$)
TRF-1448	Matching coil for SAW filter (F1034)	10mm		Inductance : $L = 1.33\mu H (\pm 5\%)$ No load Q : $Q_U = 39 (\pm 20\%)$

X'tal

For PAL 4.433619MHz
 Frequency deflection ± 25 ppm
 Temperature characteristics ± 30 ppm (- 10~75°C)
 Load capacitance 16pF
 Recommended Nihon Denpa Industries NR-18

1H delay line

Nominal frequency 4.433619MHz (f_0)
 Insertion loss 10 ± 3 dB (at f_0), delay time 63, 945 μ s
 3dB band $f_0 \pm 1.0$ MHz 以上
 Unwanted reflection 32dB 以上 ($f_0 \pm 1$ MHz 内)
 Recommended Matsushita Denshi EFD-ED 645A41T

32f_H ceramic oscillator

Recommended Murata Manufacturing Co., Ltd. CSB503F30

Delay line

TRF2036

Delay time 600ns $\pm 7\%$
 Characteristic impedance 1.6k Ω $\pm 10\%$

Frequency characteristics

Frequency (MHz)	3.0	4.0	4.43
Attenuation (dB)	2 \pm 1.5	6 \pm 2	25 or higher

APPLICATION CIRCUIT

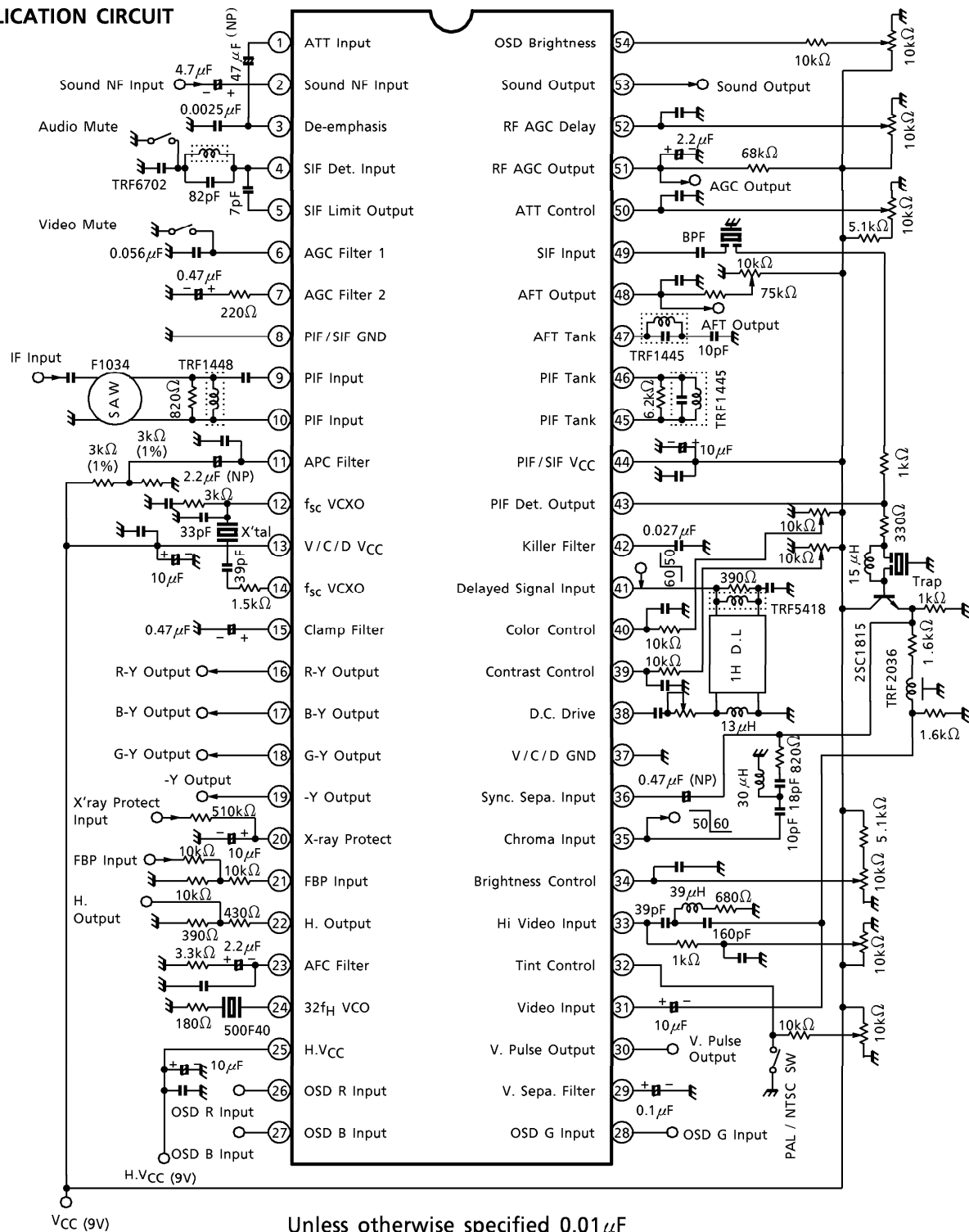

OUTLINE DRAWING
SDIP54-P-600-1.78

Unit : mm

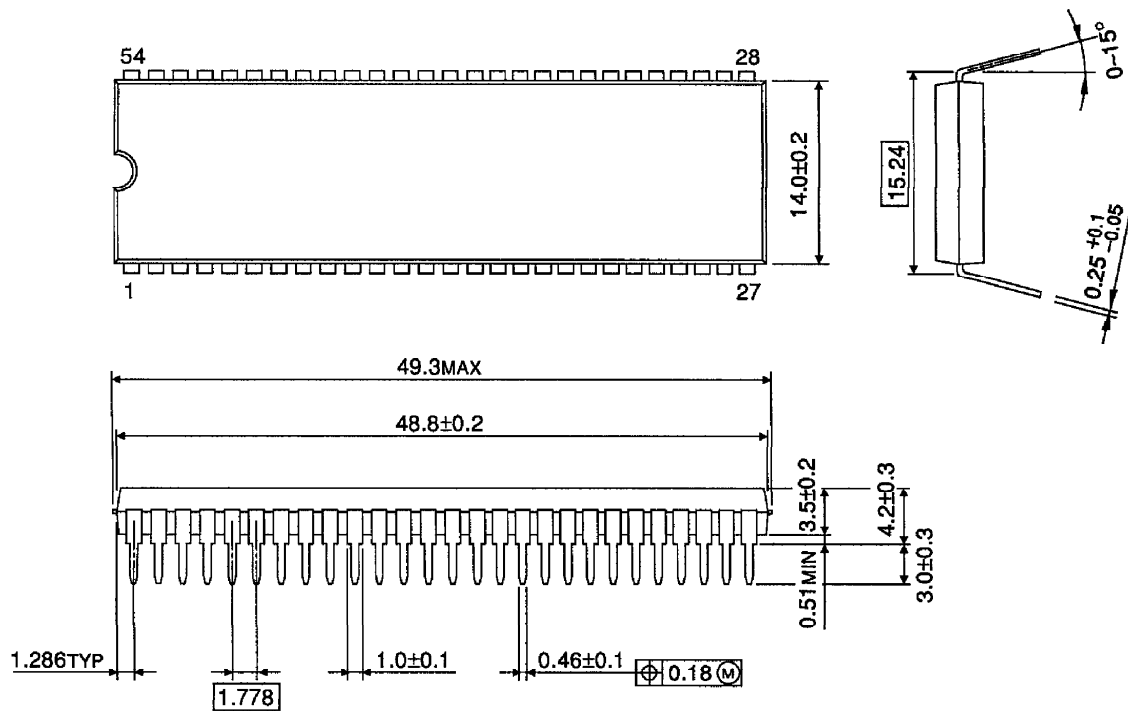

Weight : 5.44g (Typ.)